

Design of Hybrid Microgrid PV/Wind/Diesel/Battery System: Case Study for Rabat and Baghdad

M. Kharrich¹, O.H. Mohammed^{2,*} and M. Akherraz¹

¹Mohammed V University, Mohammadia School of Engineers, Ibn Sina Street P.B 765, Rabat, Morocco

²Northern Technical University, Technical College of Mosul, Mosul 41002, Iraq

Abstract

The hybrid small grid system is a solution to many economic and environmental problems. The pre-feasibility of the project is a necessary step to validate the implementation of any project. Microgrid hybrid systems (consisting of PV, wind turbines, diesel generators, and battery storage) were examined in two countries to determine their optimal economic and size. In this paper, the technical-economic was implemented as an objective function based on net present cost NPC, with respecting many constraints such as LPSP, availability, and the renewable fraction. The optimization performed using a smart and efficient algorithm called the PSO algorithm. The results indicate that the building of a microgrid hybrid system in Baghdad is more economical compared to Rabat with the same corresponding components of renewable energies and load capacity. The resulting total showed that the cost of the project reached 31K dollars for the city of Baghdad, while the cost touched 43K dollars for the city of Rabat.

Keywords: Hybrid microgrid system, Renewable energy, Energy management, Loss of power supply probability, Optimal economic, Net present cost, PSO algorithm.

Received on 25 November 2019, accepted on 11 January 2020, published on 14 January 2020

Copyright © 2020 M. Kharrich *et al.*, licensed to EAI. This is an open access article distributed under the terms of the Creative Commons Attribution licence (<http://creativecommons.org/licenses/by/3.0/>), which permits unlimited use, distribution and reproduction in any medium so long as the original work is properly cited.

doi: 10.4108/eai.13-7-2018.162692

1. Introduction

The industrial boom in the world and the increase in population growth led to the rise in energy consumption, and this crisis was accompanied by an increase in environmental problems and an economic crisis related to fuel shortages. All of these led to the emergence of an urgent need to consider clean energy sources that would be a substitute or auxiliary to traditional energies to bridge the shortfall in the world's energy needs. However, clean energies suffer from many disadvantages related to their instability due to their reliance on weather fluctuations. Therefore, it is necessary to integrate renewable energy sources with traditional sources of energy to build a hybrid system that will improve system reliability and support the system [1-3]. The Microgrid system provides an economical, efficient, and flexible solution to supply the

electricity for remote areas and isolated grid, especially since more than one-fifth of the world's population lives in islands and remote regions. And it is difficult to provide their daily electricity consumption. Renewable energies are used with traditional energies as the diesel generator in some microgrid systems to meet the load in small formations.

Despite the significant development in renewable energies to be more economical, traditional energies are still less expensive compared with renewable energies. This problem is pushing the world forward to make more efforts to reduce financial costs and reduce the risks of pollution in the environment due to the emissions from traditional sources [4-6]. Many studies have been carried out for the use of hybrid microgrid to supply electricity into areas and villages far from the national grid. Most small hybrid systems consist of solar cells, wind generators, sea turbines, and diesel generators with batteries. Many studies

*Corresponding author. Omar.hazem@ntu.edu.iq

and research used these hybrid systems in multiple goals, such as improve the microgrid systems, increase the efficiency of the system, optimal sizing, and minimum total cost. The authors used various software, linear programs, nonlinear programs, and smart algorithms. From that popular software used, Hybrid2, E Huga, TRNSYS, Homer, and RETScreen software, and from the famous algorithms used in achieving the optimization are GA algorithms, PSO algorithms, and Artificial Bee Colony (ABC) Algorithm, etc. [7-12].

The authors in [13] proposed a techno-economic optimal design model and employed the flame and water cycle optimization algorithms to decrease the total net present cost. The sensitivity analysis is used to investigate the feasibility of the suggested design based on loss of load probability. In [14], the authors used the Flower Pollination Algorithm (FPA) to deals with a techno-economic feasibility study, the hybrid system based on photovoltaics and fuel cell used to feed the electricity to the isolated areas and urban regions. A multi-objective crow search algorithm in [15] applied to optimize a hybrid system. The operating reserve was used to enhance the reliability by taking into consideration uncertainty in the size optimization and the emission. Finally, the authors in [16] suggested designing and implemented a hybrid system consists of (PV/wind/battery) using a non-dominated sorting genetic algorithm-II. The paper identified two main objectives, which are the optimal total net present cost and a reliability indicator named maximum expected energy not supplied.

This study focuses on the optimal economic cost of establishing two-hybrid microgrid systems in two different countries to feed an electrical load using PSO algorithms. The proposed system was composed of PV, wind turbine, diesel generator, and battery. The technical and economical approach implemented was based on NPC objective function and considering some constraints such as LPSP, availability, and the renewable fraction.

The results indicate that performing a hybrid microgrid system in Baghdad more economical compared to Rabat with the same load capacity and corresponding components of renewable energies in all international economic specifications. The total cost of the project reached in Baghdad 31K dollars, while the price in Rabat touched in the same project to 43K dollars.

This paper is structured as follows: Section 2 describes in detail the mathematical modeling of the hybrid microgrid system PV/wind/diesel/battery. Section 3 presents the economic evaluation based on the net present cost and the power management strategy. Section 4 offers some information about the Particle swarm optimization algorithm. Section 5 presents the results and discussions. Finally, section 6 summarizes the conclusions of this paper.

2. Hybrid system modeling

2.1. PV modeling

The output power of the Photovoltaics (PV) is based on the irradiation I , PV efficiency and PV area (A_{pv}). The PV output power is expressed as follow [17]:

$$P_{pv}(t) = I(t) \eta_r \eta_t A_{pv} \left[1 - \beta (T_a(t) - T_r) - \beta I(t) \left(\frac{NOCT-20}{800} \right) (1 - \eta_r \eta_t) \right] \quad (1)$$

where η_r is the reference efficiency, η_t is the efficiency of the MPPT equipment, β is the temperature coefficient of the efficiency varying from 0.004 to 0.006 per °C, T_a is the ambient temperature (°C), T_r is the PV cell reference temperature (°C) and $NOCT$ is the nominal operating cell temperature (°C).

2.2. Wind turbine modelling

The output power of the wind turbine is based on three conditions and expressed as follow [18, 19]:

$$P_{wind} = \begin{cases} 0, & V(t) \leq V_{ci}, V(t) \geq V_{co} \\ a V(t)^3 - b P_r, & V_{ci} < V(t) < V_r \\ P_r, & V_r < V(t) < V_{co} \end{cases} \quad (2)$$

$$\begin{cases} a = P_r / (V_r^3 - V_{ci}^3) \\ b = V_{ci}^3 / (V_r^3 - V_{ci}^3) \end{cases} \quad (3)$$

where a and b are two parameters, V_{ci} and V_{co} are cut-in and cut-out wind speed, respectively, V_r is the rated wind speed. The rated power of the wind turbine P_r is calculated as follow:

$$P_r = \frac{1}{2} \rho(t) A_{wind} C_p V_r^3(t) \quad (4)$$

where ρ represents the air density, A_{wind} is the swept area of the wind turbine and C_p is the maximum power coefficient ranging from 0.25 to 0.45%.

2.3. Diesel generator modelling

The fuel consumption of diesel generator F_{dg} depends on the output power $P_{dg,out}$, rated power P_{dg} and the parameters A_g and B_g which are a typical values expressed the linear characteristic of the fuel consumption which approximately take 0.246179 and 0.08415, respectively. The fuel consumption is expressible as follows [20]:

$$F_{dg}(t) = B_g P_{dg} + A_g P_{dg,out} \quad (5)$$

2.4. Battery storage modeling

The battery capacity is based on load demand E_l and battery daily autonomy AD . The battery capacity is expressed as follows [9, 20]:

$$P_{Cap_bat} = \frac{E_{load} AD}{DOD \eta_{inv} \eta_b} \quad (6)$$

3. Economical and optimization model

3.1. Net present cost

The net present cost (*NPC*) is an important element of the microgrid system design. The *NPC* over project lifetime and represents the sum of the capital (*C*), operation & maintenance (*OM*), replacement (*R*) costs for each component, plus the fuel cost for the diesel (FC_{dg}), therefore all values are presented in dollars. To increase the accuracy of the economic calculations there are important parameters since the rate of the interest, the inflation rate, and the escalation rate. The *NPC* can be calculated as follows [21, 22]:

$$NPC = C + OM + R + FC_{dg} \quad (7)$$

3.2. Levelized cost of energy

The Levelized Cost of Energy (LCOE) is an important economic factor that evaluates the cost of each kilowatt in each hour. The capital recovery factor should be calculated to convert the initial cost to the annual capital cost. The LCOE is calculated using the formula as in [20].

3.3. Loss of power supply probability

Loss of power supply probability (LPSP) is defined as the reliability of the system. When the LPSP is 1 it means that the load will never be satisfied, and when the LPSP is zero it means that the load will be always satisfied [20].

3.4. Renewable Fraction

The renewable fraction (*RF*) is the fraction of the energy delivered to the load that originated from renewable resources, The *RF* is expressed as follow [20]:

$$RF = \left(1 - \frac{\sum_{t=1}^{8760} P_{dg,out}(t)}{\sum_{t=1}^{8760} P_{re}(t)}\right) \times 100 \quad (8)$$

where P_{re} indicates the sum of PV and wind powers.

3.5. Availability

The availability index *A* determine the merit of the proposed system design which presents the satisfaction of the load. The availability can be formulated as [21]:

$$A = 1 - \left(\frac{P_{bmin}(t) - P_b(t) - (P_{pv}(t) + P_{wind}(t) + P_{dg,out}(t) - P_{load}(t)) u(t)}{\sum_{t=1}^{8760} P_{load}(t)} \right) \quad (9)$$

where $u(t)$ takes 0 if the demand is meeting else it takes 1, P_b is the state of charge of the battery, P_{bmin} is minimum charge of the battery.

3.6. Renewable Fraction

The renewable resources of PV and wind are based on the weather data which are unstable, that impose to introduce the diesel generator in order to enhance the system reliability and efficiency. The energy management strategy includes many scenarios, for example, the electrical load is supplied with the energy needed by discharging the battery energy stored in the system when the renewable energy sources are unable to meet the electrical load. Also, in the event of an excess of power and the battery fully charged, the excess energy is eliminated by the damping system to protect the battery from overcharging. The following cases are considered in the power management strategy [20, 23]:

- **Case 1:** The battery will charge when the load is satisfied by all renewable energies.
- **Case 2:** When renewable energies are not able to respond to the load, the load will be satisfied by the battery.
- **Case 3:** The diesel generator is used to supply the load when renewable energies and battery bank are not able to satisfy the load.
- **Case 4:** When the battery fully charged, the excess power will be damped by the damping system.

3.7. Inequality constraints

The system becomes highly controlled and satisfied by considering the economic and environmental aspects. Besides, respecting the constraints gives high reliability and good system availability.

4. Particle swarm optimization algorithm

The improved particle swarm algorithm (PSO) is attributed to Kennedy and Eberhart. This algorithm suggests simulating the social behavior of some organisms, such as birds and fish. It is done by modeling the movement of those organisms. The PSO is a metaheuristic that is used heavily in different fields and has been programmed as a computational method based on iteration for enhancing the best solution. The PSO particles are changed randomly in each iteration using the velocity and position equations [24,25]. In this paper, the PSO algorithm was applied to obtain the optimal economic model of the hybrid system as the steps shown in Fig.1.

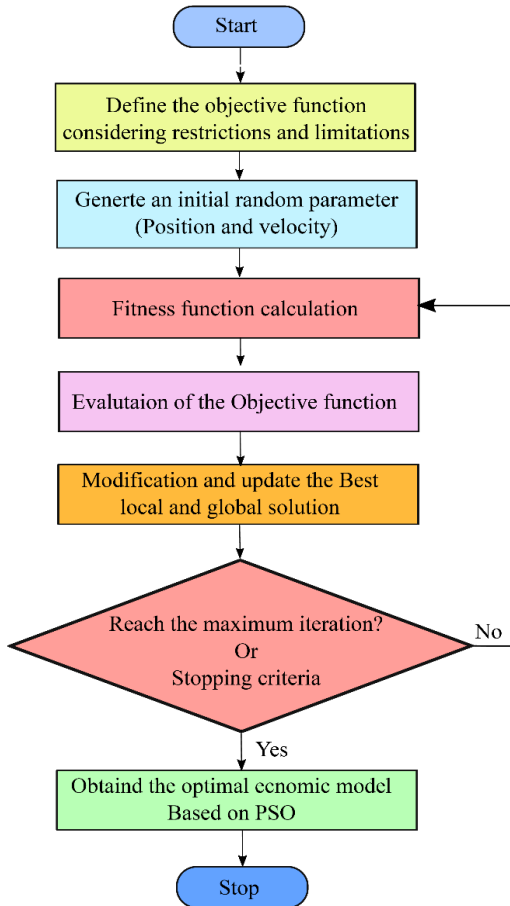

Figure 1. Flowchart of PSO algorithm

5. Results and discussion

The design of the hybrid microgrid system has been proposed in two positions to determine the pre-economic feasibility of the project. The first location in Rabat, Morocco (33°56'38.148" N, 6 °51 '1.691 " O), while the second is Baghdad in Iraq (33°22'30.972 " N, 44° 14' 21.804" E) as shown in Fig.2. This system based on PV, wind, battery storage, and diesel, as illustrated in Fig.3, and the capacitance for the assumed electrical load is the same in both locations, which is shown in Fig.4. The weather variations are given by wind speed, solar radiation, temperature, and pressure, as shown in Fig.5 (a, b, c, d), respectively. The input parameters of economic data are presented in Table 1, while the PV, wind, battery, diesel and inverter data are presented in Tables 2, 3, 4, 5, 6, respectively. The economic values are revealed the approximate values from [17, 22].

Table 7 presents the constraints which can give a robust design by ensuring high availability of power and excellent reliability of the system, all with a high penetration of renewable energies. The hybrid system is optimized used the PSO algorithm, which has been coded using MATLAB/Editor. The algorithm used ten populations with a variable inertia weight and a maximum iteration of 100. Fig.6 gives the NPC variation

independently for each location, in which Baghdad has the minimum project finance with 31275\$. Table 8 presents the variables of design in each location, which characterize approximately by the same climate. The solar radiation is better in Baghdad, while the wind speeds higher in Rabat. The sizes of batteries and diesel generators are almost the same in the two locations that are used as a backup. Table 9 presents the values of the factor of each location, the NPC and LCOE in Baghdad are better than Rabat with 31K \$ and 0.23 \$/kWh, respectively, the other indices are approximately the same. The annual power system evaluation parameters in (Kw) are given in Table 10.

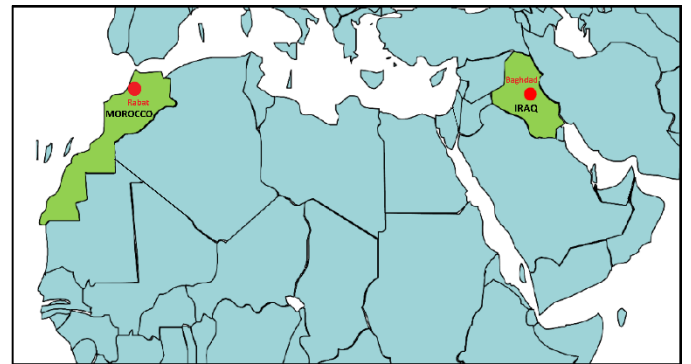

Figure 2. Locations under study

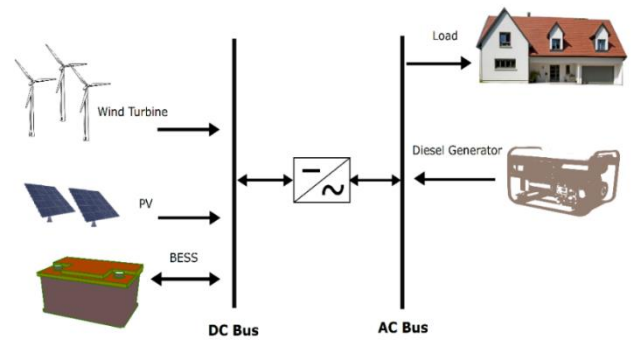

Figure 3. Microgrid Hybrid system

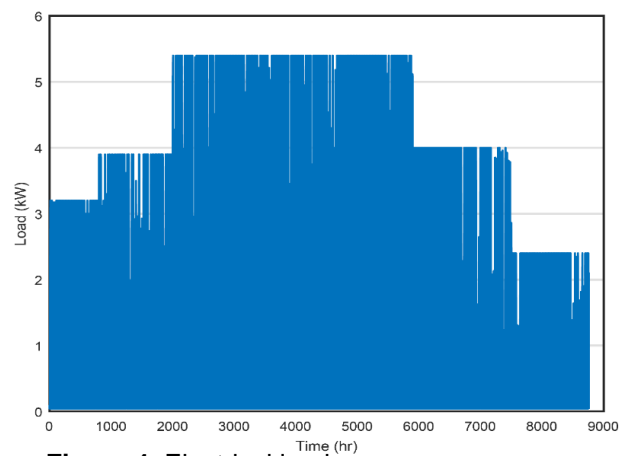

Figure 4. Electrical load

Table 1. Input parameter of economic data

Battery initial cost	85	\$/kWh
Annual operation & maintenance cost of battery	0.03× Battery initial cost	\$/kWh/year
Depth of discharge	80	%
Battery efficiency	85	%
Minimum charge of the battery	20	%
Maximum charge of the battery	80	%
Battery system lifetime	5	year

Table 2. PV parameters

PV initial cost	325	\$/m ²
Annual O&M cost of PV	0.01× PV initial cost	\$/m ² /year
Reference efficiency of the PV	15	%
Efficiency of MPPT	100	%
PV cell reference temperature	25	°C
Temperature coefficient	0.005	°C
Nominal operating cell temperature	47	°C
PV system lifetime	20	year

Table 3. Wind parameters

Wind initial cost	85	\$/m ²
Annual O&M cost of wind	0.01× Wind initial cost	\$/m ² /year
Maximum power coefficient	0.4	%
Cut-in wind speed	3	m/s
Cut-out wind speed	25	m/s
Rated wind speed	11	m/s
Wind system lifetime	20	year

Table 4. Battery parameters

Project lifetime	20	year
Interest rate	6	%
Escalation rate	7.5	%
Inflation rate	8	%

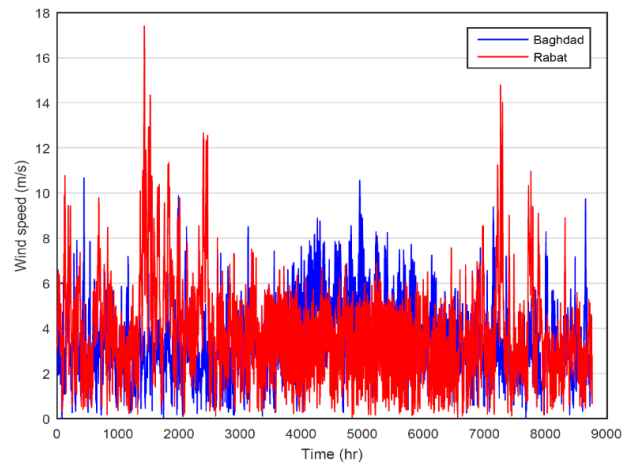

(a) Wind speed

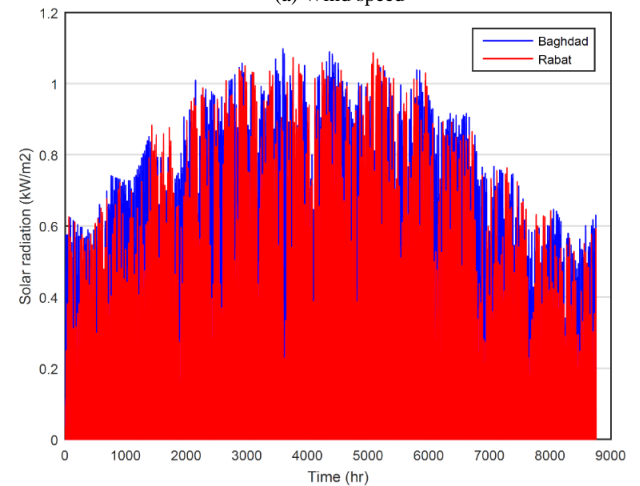

(b) Solar radiation

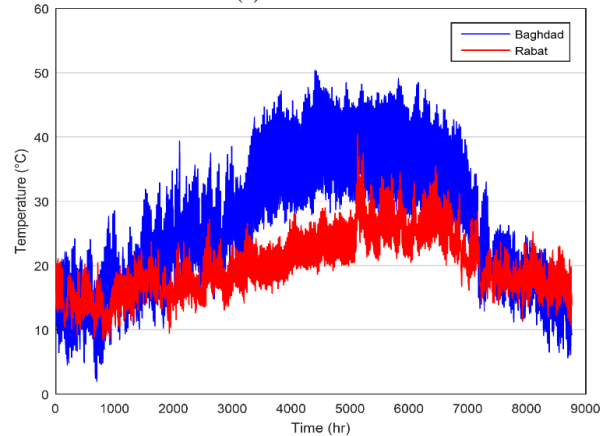

(c) Temperature

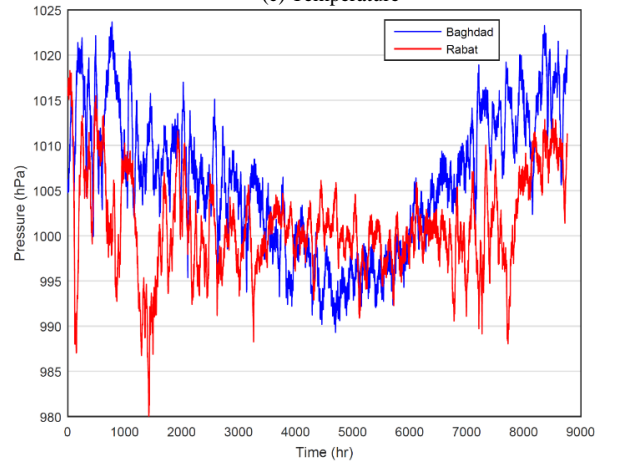

(d) Pressure

Figure 5. Weather data of locations under study
EAI Endorsed Transactions on
Energy Web
Online First

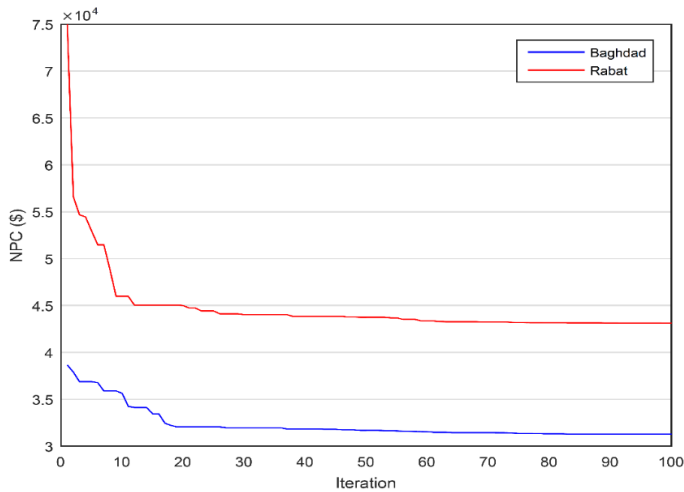

Figure 6. Convergence of NPC

Table 5. Diesel parameters

Diesel initial cost	260	\$/kW
Annual O&M cost of diesel	0.05	\$/h
Replacement cost	210	\$/kW
Fuel price in Rabat	1.04	\$/L
Fuel price in Baghdad	0.63	\$/L
Diesel system lifetime	7	year

Table 6. Inverter parameters

Inverter initial cost	400	\$/m ²
Annual O&M cost of inverter	20	\$/year
Inverter efficiency	97	%

Table 7. Constraints parameters

Maximum PV area	80	m ²
Maximum wind-swept area	80	m ²
Maximum rated power of diesel generator	5	kW
Maximum nominal capacity of battery	5	kWh
Maximum loss of power supply probability	5	%
Minimum renewable fraction	70	%
Minimum Availability	95	%

Table 8. Design results

Location	A_{pv} (m ²)	A_{wind} (m ²)	C_{bat} (kWh)	P_{dg} (kW)
Baghdad	51.7886	16.8770	2.0253	0.0433
Rabat	72.4326	37.3371	2.0256	0.0414

Table 9. Factors Results

Location	NPC (\$)	LCOE (\$/kWh)	LPSP (%)	A (%)	RF (%)	AD
Baghdad	31275	0.2330	0.05	97.10	99.345	1
Rabat	43134	0.3214	0.05	96.94	99.596	1

5.1. Power damping system

When the energy generated via the hybrid system is not used and is not stored, it will be damped by being sent to the damping system consisting of an electrical resistance heater or water-air heater. Fig.7 shows the power damped in Rabat and Baghdad, where the power damped in Rabat is 13544 kW/year while the power damped in Baghdad is 5129.8 kW/year as in Table 10.

5.2. Rabat microgrid system

Morocco is located in Africa, known by the right weather conditions such as solar radiation and wind speed. Fig.8(a) presents the output power of the hybrid system over one year in Rabat, which showed the PV panels are the most produced energy, mainly in the middle of that year. The wind turbine delivered high energy at the beginning and the last of that year. The battery and the diesel produce a small energy capacity over this year to enhance the system efficiency. Fig.9(a) presents the portions of the energy supplied in the system from each component. The PV is the pillar supplier of the system with 73%, and the wind gives 25%, the diesel supplies just 0.5% with the battery discharge of 1.5%. The detailed study of costs is resented in Fig.10(a), which the capital cost of the PV is the prohibitive cost with 23K \$, the operation and maintenance of the PV is also expensive with 5.4K \$. We also notice that the operation and maintenance of the diesel are costly compared with it is capital or replacement costs. The fuel cost is 1.4K \$ annually.

5.3. Baghdad microgrid system

Iraq is located in Asia, known by excellent solar irradiation. Fig.8(b) presents the output power over a year in Baghdad, PV is the most produced component, while the wind turbine produces lower energy and seasonal. Fig.9(b) presents the portions of the energy supplied in the system from each element; The PV is the pillar with 84% while the wind gives just 11%. The detailed study of costs is presented in Fig.10(b), in which the capital cost of the PV is the prohibitive cost with 16K \$, the operation and maintenance of the PV is also expensive with 4K \$. Although the fuel price in Baghdad lower, the fuel cost is 906 \$ for approximately 59 L consumed annually.

5.4. Sensitivity analysis

In this part, the impacts of hybrid component sizing variation on the NPC and power availability are discussed. Fig.11(a,b) shows the effect of component resizing on the NPC, which indicates that any change in the component size can change NPC approximately with almost the same effect. The minimum +20% variation is for the PV will reach an NPC of 48K \$, and the maximum +20% variation is for the diesel generator will contact an NPC of

50K \$ for Rabat location, in the other side, the PV variation profoundly impacts on the total cost in Baghdad. However, Fig.12(a, b) shows the impact of the component resizing on the availability, indicating that the PV is significant for both locations, which knowing with excellent solar radiation. In contrast, the other components cannot impact the availability of energy.

6. Conclusion

The hybrid microgrid system is an economically cost-effective project that can be entirely adapted mainly in developing countries. Rabat and Baghdad are known for the sunny climate, while the good wind speeds are mostly in Rabat. The proposed hybrid system is based on PV, wind, diesel, and battery.

The results indicate that the hybrid system in Baghdad is more economical cost-effective with an NPC of 31K\$ and LCOE of 0.2330 \$/kWh, which means that the weather conditions in Baghdad are more favourable than of Rabat. The detailed economic study demonstrated that the PV capital cost is the more expensive cost comparing with the

total cost, it is 23K\$ in Rabat and 16K\$ in Baghdad. The PSO optimization was implemented with consideration of all constraints gives a high availability of power, excellent reliability of the system, and high penetration of renewable energy. The damping power is determined, which is damped by using the electrical resistance and water-air heater. Sensitivity analysis is employed to study the impact of resizing components on the NPC and its availability.

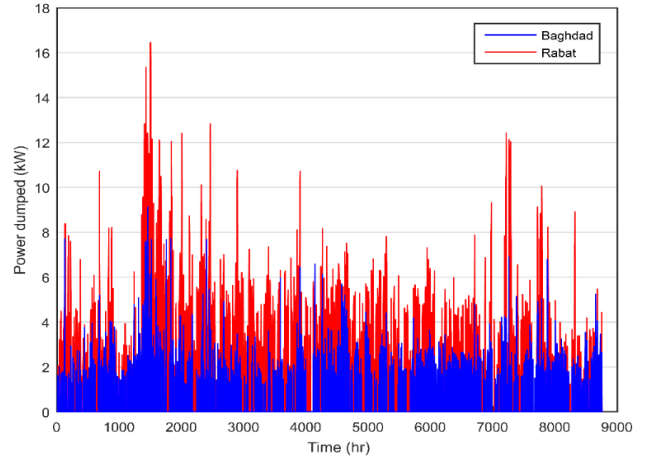

Figure 7. Damping power in Rabat and Baghdad

Table 10. Annual power system evaluation in (Kw)

Location	P_{pv}	P_{wind}	$P_{dg,out}$	$P_{battery}$	$P_{tot,generated}$	Unmet load	Damped power
Baghdad	15326	1961.9	113.15	468.44	17869.49	584	5129.8
Rabat	19573	6618	105.77	495.9	26793.67	585	13544

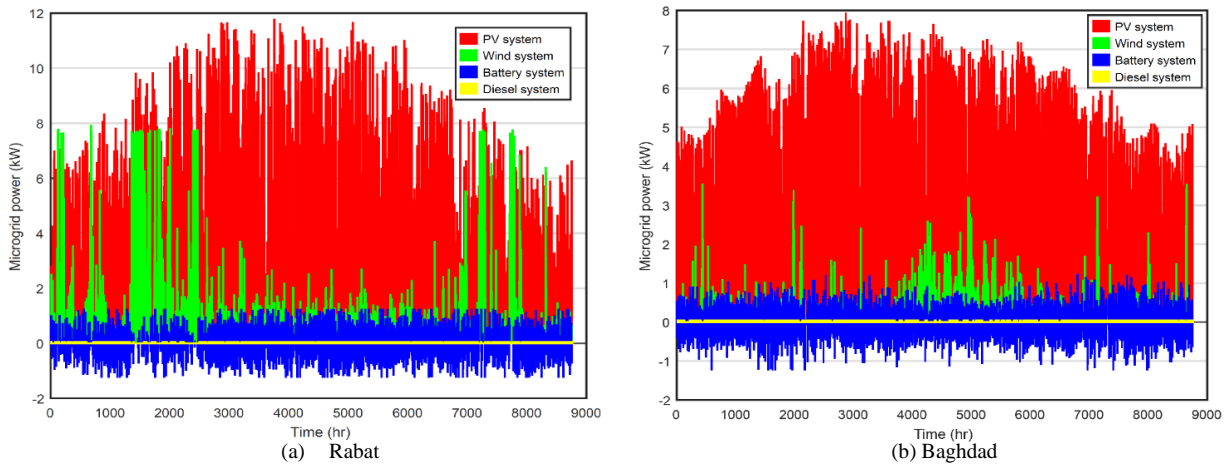

Figure 8. Output power over a year

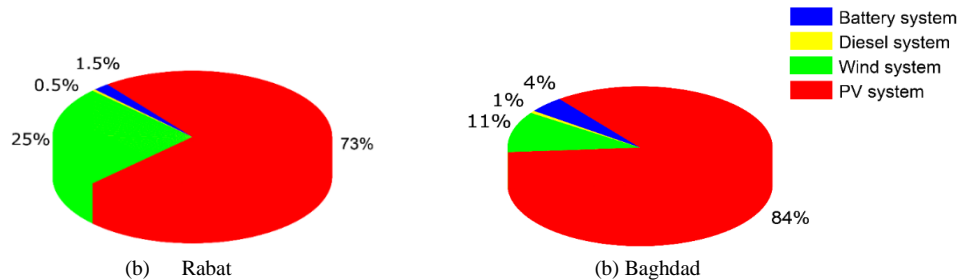

Figure 9. Contribution of system components to energy production

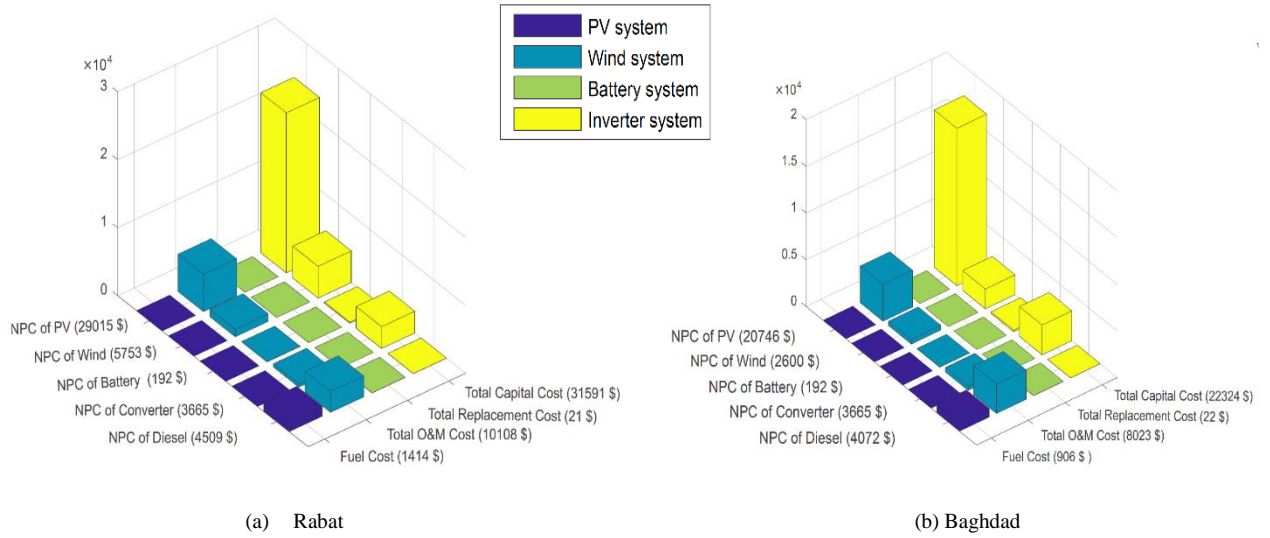

Figure 10. Project construction costs

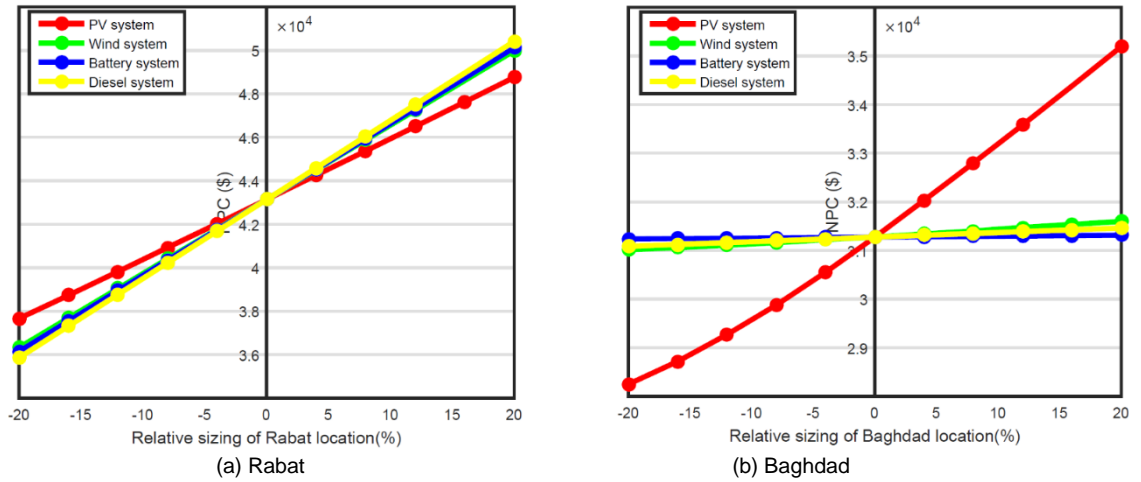

Figure 11. Sensitivity analysis of NPC

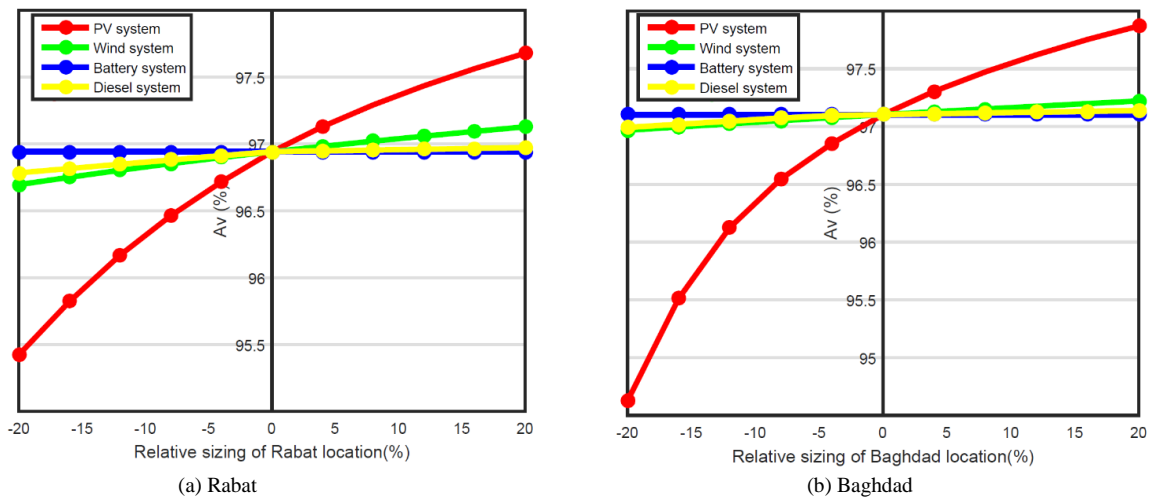

Figure 12. Sensitivity analysis of availability

References

- [1] Livshitz, I. I., Lontsikh, P. A., & Kunakov, E. P. (2019). Application of a Hybrid Method for Key Energy Facilities Safety Assessment. *EAI Endorsed Transactions on Energy Web*, 6(22).
- [2] Tazvinga, H., & Dzobo, O. (2017). Hybrid energy systems for rural communities in Zimbabwe.
- [3] Mohammed, O.H., Amirat, Y., Feld, G., Benbouzid, M., 2016. Hybrid generation systems planning expansion forecast state of the art review: Optimal design vs technical and economical constraints. *J. Electr. Syst.* 12.
- [4] Sadio, A., Mbodji, S., & Fall, I. (2018). New numerical sizing approach of a standalone photovoltaic power at Ngoundiane, Senegal. *EAI Endorsed Transactions on Energy Web*, 5(16).
- [5] Mohammed, O.H., 2019. Optimal Hybridisation of a Renewable System to Fulfill Residential Electrical Load: In Mosul, Iraq, in: 2018 3rd Scientific Conference of Electrical Engineering, SCEE 2018. pp. 209–213.
- [6] Chouaib, A., Messaoud, H., & Salim, M. (2017). Sizing, modelling and simulation for Hybrid Central PV/wind turbine/diesel generator for feeding rural village in South Algeria. *EAI Endorsed Transactions on Energy Web*, 4(15).
- [7] Alghamdi, A. H. S., Castro, C. H. M. R., & Zamora, R. (2018, April). Review of Cost Optimization of Electricity Supply by Using HOMER and a Case Study for a Big Commercial Customer in Brazilian Amazon Area. In *International Conference on Smart Grid Inspired Future Technologies* (pp. 220-229). Springer, Cham.
- [8] Sadio, A., Mbodji, S., Fall, I., & Sow, P. L. T. (2019). A comparative study based on the Genetic Algorithm (GA) method for the optimal sizing of the standalone photovoltaic system in the Ngoundiane site. *EAI Endorsed Trans. Energy Web*, 6(21), e1.
- [9] Abushnaf, J., Rassau, A., 2018. Impact of energy management system on the sizing of a grid-connected PV/Battery system. *Electr. J.* 31, 58–66.
- [10] Haratian, M., Tabibi, P., Sadeghi, M., Vaseghi, B., Poustdouz, A., 2018. A renewable energy solution for standalone power generation: A case study of KhshU Site-Iran. *Renew. Energy*.
- [11] Mohammed, O.H., Amirat, Y., Benbouzid, M., 2019. Particle Swarm Optimization Of a Hybrid Wind/Tidal/PV/Battery Energy System. Application To a Remote Area In Bretagne, France. *Energy Procedia, Emerging and Renewable Energy: Generation and Automation* 162, 87–96.
- [12] Mohammed, O.H., Amirat, Y., Benbouzid, M., 2018. Economical Evaluation and Optimal Energy Management of a Stand-Alone Hybrid Energy System Handling in Genetic Algorithm Strategies. *Electronics* 7, 233.
- [13] Das, M., Singh, M.A.K., Biswas, A., 2019. Techno-economic optimization of an off-grid hybrid renewable energy system using metaheuristic optimization approaches – Case of a radio transmitter station in India. *Energy Convers. Manag.* 185, 339–352.
- [14] Samy, M.M., Barakat, S., Ramadan, H.S., 2019. A flower pollination optimization algorithm for an off-grid PV-Fuel cell hybrid renewable system. *Int. J. Hydrogen Energy* 44, 2141–2152.
- [15] Jamshidi, M., Askarzadeh, A., 2019. Techno-economic analysis and size optimization of an off-grid hybrid photovoltaic, fuel cell and diesel generator system. *Sustain. Cities Soc.* 44, 310–320.
- [16] Acuña, L.G., Lake, M., Padilla, R.V., Lim, Y.Y., Ponzón, E.G., Soo Too, Y.C., 2018. Modelling autonomous hybrid photovoltaic-wind energy systems under a new reliability approach. *Energy Convers. Manag.* 172, 357–369.
- [17] Heydari, A., Askarzadeh, A., 2016. Optimization of a biomass-based photovoltaic power plant for an off-grid application subject to loss of power supply probability concept. *Appl. Energy* 165, 601–611.
- [18] Guangqian, D., Bekhrad, K., Azarikhah, P., Maleki, A., 2018. A hybrid algorithm based optimization on modeling of grid independent biodiesel-based hybrid solar/wind systems. *Renew. Energy* 122, 551–560.
- [19] Hatata, A.Y., Osman, G., Aladl, M.M., 2018. An optimization method for sizing a solar/wind/battery hybrid power system based on the artificial immune system. *Sustain. Energy Technol. Assessments* 27, 83–93.
- [20] Ramli, M.A.M., Boucekara, H.R.E.H., Alghamdi, A.S., 2018. Optimal sizing of {PV}/wind/diesel hybrid microgrid system using multi-objective self-adaptive differential evolution algorithm. *Renew. Energy* 121, 400–411.
- [21] Ghiasi, M., 2019. Detailed study, multi-objective optimization, and design of an {AC}-{DC} smart microgrid with hybrid renewable energy resources. *Energy* 169, 496–507.
- [22] Movahediyani, Z., Askarzadeh, A., 2018. Multi-objective optimization framework of a photovoltaic-diesel generator hybrid energy system considering operating reserve. *Sustain. Cities Soc.* 41, 1–12.
- [23] Mohammed, O.H., Amirat, Y., Benbouzid, M.E.H., Feld, G., 2017. Optimal design and energy management of a hybrid power generation system based on wind/tidal/PV sources: Case study for the ouessant French Island, *Green Energy and Technology*. https://doi.org/10.1007/978-3-319-50197-0_12
- [24] Lu, Y., Liang, M., Ye, Z., Cao, L., 2015. Improved particle swarm optimization algorithm and its application in text feature selection. *Appl. Soft Comput.* 35, 629–636.
- [25] Parsopoulos, K.E., Vrahatis, M.N., 2004. On the Computation of All Global Minimizers Through Particle Swarm Optimization. *IEEE Trans. Evol. Comput.* 8, 211–224.