

Measurements of Radon Concentrations and Dose Assessments in Chemistry Department-Science College- Al-Mustansiriyah University, Baghdad, Iraq

Iman Tarik Al-Alawy *¹, Haider Rayed Fadhil ²

*¹Physics Department, College of Science, Al-Mustansiriyah University/Baghdad, Iraq

²Ministry of Science and Technology, City, Baghdad, Iraq

ABSTRACT

Measurements of radon gas concentrations with their progeny and the annual effective dose indoor the building of Al-Mustansiriyah University College of Science-Chemistry Department have been carried out by using time-integrated passive radon dosimeters solid state nuclear track detector CR-39 technique. The detectors with 1cm x1cm have been distributed over 58 places and suspended for sitting (1m) and standing (1.75m) positions in each location under study. The dosimetric measurements are made over a period of 100 days from 30 January 2014 to 10 May 2014. The calibration process has been done using radium-226 source with known activity radiation. It has found that the indoor radon gas concentrations varying from $35.220 \pm 5.935 \text{ Bq/m}^3$ to $71.673 \pm 8.466 \text{ Bq/m}^3$ with an average value $49.129 \pm 6.969 \text{ Bq/m}^3$ at 1m, and varying from $31.794 \pm 5.639 \text{ Bq/m}^3$ to $68.246 \pm 8.261 \text{ Bq/m}^3$ with an average value $45.487 \pm 6.696 \text{ Bq/m}^3$ at 1.75m which are within the worldwide limits 148 Bq/m^3 (EPA, 2003) and $200-300 \text{ Bq/m}^3$ (ICRP, 2009). The annual effective dose of the inhalation exposure to radon gas has been estimated and this vary from 0.370 mSv/y to 0.753 mSv/y with an average value 0.516 mSv/y at 1m, and varying from 0.334 mSv/y to 0.717 mSv/y with an average value 0.478 mSv/y at 1.75m which are within the worldwide permissible limits $3-10 \text{ mSv/y}$ (ICRP, 1993). The potential alpha energy concentration found to vary from 3.808 mWL to 7.748 mWL with an average value 5.311 mWL at 1m and vary from 3.437 mWL to 7.378 mWL with an average value 4.918 mWL at 1.75m which are less than the recommended value 53.33 mWL (UNSCEAR, 1993). The lung cancer cases per million person per year vary from 6.664 to 13.562 per million person per year with an average value 9.296 per million person per year at 1m and vary from 6.016 to 12.913 per million person per year with an average value 8.607 per million person per year which are less than the recommended range 170-230 per million person per year (ICRP, 1993). The number of decays per-minute using swabs measurements technique have been used for selected units within two swabs from building materials walls for each unite, with area of 100 cm^2 using Ludlum 3030, the average of three swabs measurements have been calculated. Hence, the effectiveness of emitted alpha particles from the walls has been calculated to be varied from 0.00556 to 0.02222 Bq/cm^2 with an average value 0.01154 Bq/cm^2 at 1m and 0.00000 Bq/cm^2 to 0.01667 Bq/cm^2 with an average value 0.00983 Bq/cm^2 at 1.75m respectively which is within the permissible limit 0.04 Bq/cm^2 (Danial, 2010).

Keywords: Indoor Radon gas; Natural radioactivity; CR-39 detector; Annual effective dose; Ludlum 3030

I. INTRODUCTION

Radon was the fifth radioactive natural element being found as a noble gas, which was discovered by the German Physicist Friedrich Ernst Dron in (1900), who called it Niton. It has been called radon since (1923). Its atomic number is 86 and mass number is 222 in the

periodic table [1, 2]. Radon is a gas that comes from the radioactive decay of either uranium-235 and 238 or thorium-232. All of the gaseous radon members of the three primordial series headed by U-235, U-238, and Th-232 which are common naturally occurring are radioactive alpha particle emitters [3]. The decay of radon, with uranium-238, goes through four inter-

mediate states to form radium-226 which has a half-life 1600 years. Radium-226 then decay to form radon-222 gas. Radon's half-life is 3.82 days, which provides sufficient time for it diffuse through soil and into homes, where it further disintegrates to produce the more radiologically active radon progeny (radon daughters) [2]. The name radon is Rn-222 isotope in order to distinguish it from other two natural isotopes; called thoron Rn-220 (alpha emitter of 55.6s half Life) and action Rn-219 (alpha emitter of 3.96 s half-Life) because they originate in the thorium and actinium series, respectively. Because of these properties the measurements of the alpha dose delivered from action Rn-219 and thoron Rn-220 would be the primary concern but so far these situations have been rare [2]. Because Rn-222 gas moves freely in the indoor environment, it becomes a human health hazard. If its concentration in indoor air becomes high, radon and its decay products can be inhaled and cause lung cancer. Many previous studies of indoor radon concentration have been performed with widely used of solid state nuclear track detectors (SSNTDs) [4, 5, 6, 7, 8, 9, and 10]. However, in this work the indoor radon gas concentrations using CR-39 detectors have been measured in the department of chemistry in college of science of Al-Mustansiriyah University, at which a radioactive sources are usually used in their laboratories.

II. METHODS AND MATERIAL

A. Area of the Study

Baghdad city is located in the Middle of Iraq and it is the capital of the Republic of Iraq. Its location of latitude 33.316666 and longitude 44.416668 it is located about 34meters above sea level, with a total area nearly of 204.2 km² and a population nearly of 7665292inhabitants, see Fig. 1 Baghdad city has a desert climate characterized by extreme heat during the day, an abrupt drop in temperature at night, and slight, erratic rainfall. The temperature is moderate at 12°C in winter and 33°C in summer. Its lands are flat and levelled in areas linked to waters from the Tiger River. AL- Mustansiriyah University is located in the Southern of Baghdad City, see Fig. 2. The science college and their buildings are shown in Fig. 3. The three figures are taken from Google earth.



Fig. 1. Baghdad City.

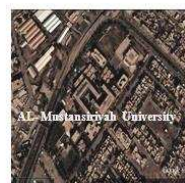

Fig. 2. AL- Mustansiriyah University.

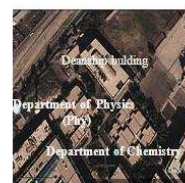

Fig. 3. The science college.

B. Measurement Technique

Radon concentrations are measured using 68 plastic cups (i.e. dosimeters) prepared with solid state nuclear track detectors CR-39 of 500µm thick, density 1.36 gm/cm³, UK issued, and 1x1 cm² area are distributed inside the rooms and laboratories of department of chemistry. 34 detectors of 68 are suspended at 1m and the others are suspended at 1.75m. Each dosimeter is to be made of a plastic cup of height 4.5cm, the diameter of the bottom is 3cm and that of the top is 4.5cm, with a circular hole of diameter 1cm in the centre, Fig. 4a shows the typical CR-39 track detectors. The hole is covered by a piece of sponge sealed into the interior surface of the lid. The detector CR-39 is fixed in the bottom of the dosimeter as shown in Fig. 4b. The detectors are left for a period of three months from 30 January 2014 to 30 April 2014. The exposed detectors are collected from different locations and etched chemically in 6.5M NaOH solution at 60°C for 6 hours. The chemical etching process to the CR-39 detectors has been done in order to show the alpha-particles tracks from ²²²Rn. Optical microscope with magnification of 400X by an objective (4x, 10x, 40x and 100x) and two eye pieces (10x) with digital video camera of 5MB resolution and connected with a personal computer to show and counting the alpha damage tracks formed on the detectors.



Fig. 4a. Typical CR-39 track detectors seen in the present work for chemistry department.

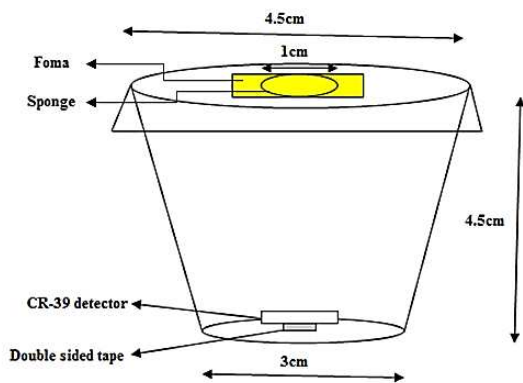

Fig. 4b. Plastic holder design (i.e.dosimeter) used in the present work.

C. Ludlum3030

The Ludlum3030 alpha-beta counter is powered by main supply of AC voltage. The instrument features a built-in detector, ZnS (Ag) adhered to plastic scintillation material, tube 5.1cm (2inch) diameter, magnetically shielding photomultiplier, window 0.4mg/cm² aluminized molar, active and open area 20.3cm², efficiency alpha 32% ²³⁰Th, 39% ²³⁸U, 37 % ²³⁹Pu, high-voltage power supply, adjustable count time periods, and a click-per-event audio with adjustable volume. A pulse height analyser is employed to provide information to the two independent counters. Filter paper for qualitative analysis made in Germany by diameter 4.5cm, used to take samples from the walls of the chemistry department building of the college of science.

D. Chemical Etching

For the preparation of etching solution, the weight of (NaOH) has been calculated as follows [11]:

$$W = W_{eq} \times N \times V \quad (1)$$

Where: *W* is the weight of NaOH needed to prepare for a given normality. *W_{eq}* is the equivalent weight of NaOH (i.e. the summation of the atomic weight of Na, O and H). i.e. $W_{eq} = 22.98977 + 15.9994 + 1.00794 = 39.99711 = 40$. *N* is the normality =6.25. *V* is the volume of distilled water (1 liter). $W = 40 \times 6.25 \times 1 = 250$ gm of NaOH in 1 liter of distilled water.

E. Microscopic Viewing

After etching and drying process the detectors have a viewing by optical microscope so as to get on the alpha particles tracks by selecting right zoom (the ability of magnification is equal to 1000 related to objective lens and camera with magnification 100 and 10 respectively) and to count the tracks per unit area. Especially glass slide have been used to calibrate the dimensions of pictures. The camera has been connected with a microscope to photograph promised tracks. The camera is connected with the computer to show pictures effects on a computer screen. The calibration of software have been done to calculates the area of field view on a glass slide in front of the lens object-oriented and to calculate the length and width of the picture, then calculate the area and divides the average number of tracks (*N_{ave}*) for the (sample X) calculated on the area of field view per unit mm² (*A*) to get the track density. Ten attempts (pictures) have been taken for each sample, otherwise to calculate the average number of tracks obtained for each sample. The track density (*ρ*) has been calculated by using the following equation [12, 13]:

$$\text{Track density } (\rho) = \frac{\text{average number of total tracks } (N_{ave})}{\text{area of field view } (A)} \quad (2)$$

F. Calibration of CR-39 Detector

The calibration of CR-39 detector has been carried out by using the standard source of radium ²²⁶Ra with radioactivity (*A*=0.1μCi=37000Bq) at manufacturing data 1-03-1982, which emits radon gas ²²²Rn. After correction the activity to *A*=36481.13Bq at 30-09-2013 and dose rate at 1cm is 63.611μSv/hr using Rad Pro software. The CR-39 detector and the standard source of radium ²²⁶Ra were placed at the special container used in the present work with a cylindrical shape and volume 0.11m³ diameter 40cm and height 85cm as shown in Fig. 4c.

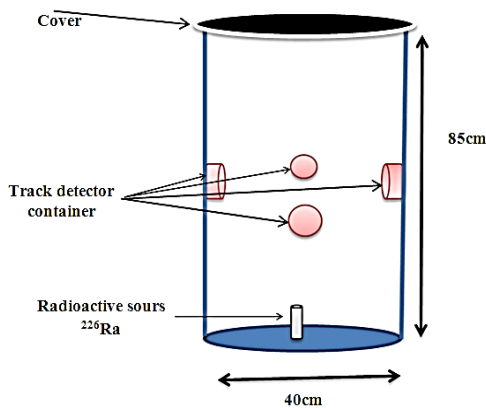

Fig. 4c. Container (cylindrical shape) used for the calibration in the present work.

The activity of radon gas (A_{Radon}) inside the container at any time can be calculated by using the following equation [14]:

$$A_{\text{Radon}} = A_{\text{Radium}} \times (1 - \exp(-\lambda_{\text{Radon}} \times t)) \quad (3)$$

Where: $t_{1/2}({}^{222}\text{Rn}) = 3.8253$ day. $A_{\text{Radium}} = 36481.1\text{Bq}$ is the activity of radium-226 as a standard source. λ_{Radon} is the decay constant of radon-222 = 0.1812 day^{-1} . t is the exposure time in day. The exposure time of detectors was with different times (0.25, 0.5, 0.7, and 1 day), then the radon exposure determined by [15]:

$$E_s (\text{Bq} \cdot \text{day}/\text{m}^3) = [A_{\text{Radon}} (\text{Bq})/V(\text{m}^3)] \times t(\text{day}) \quad (4)$$

Where E_s is the radon gas exposure (i.e. concentration) in standard source. A_{Radon} is the radioactivity of ${}^{222}\text{Rn}$ calculated by Eq. (3). V is the container volume in m^3 ; t is the exposure time in day. Fig. 5 shows the relation between the track density (ρ_s) and the radon exposure (E_s).

$$\text{Slope} = \rho_s / E_s \quad (5)$$

Where ρ_s is the track density of standard source (tracks/ mm^2). E_s is the radon exposure of standard source (Bq/m^3).days = (Bq/m^3) by multiplying with (0.25, 0.5, 0.75, and 1 day).

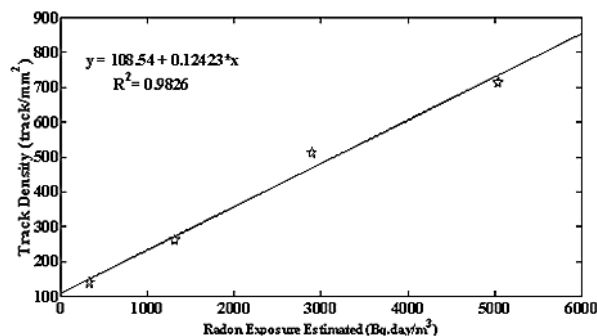

Fig. 5. Calibration curve for CR-39 detector. Track density (track/ mm^2) as a function of Radon exposure ($\text{Bq} \cdot \text{day}/\text{m}^3$).

G. Calculation of Radon Exposure

After microscopic viewing process has been done to calculate the track density. Radon gas ${}^{222}\text{Rn}$ concentration indoor has been measured by comparison between track densities on the detector around the unknown sample and that of the standard calibration source, from the following relation [15]:

$$\frac{E_x(\text{sample})}{\rho_x(\text{sample})} = \frac{E_s(\text{standard})}{\rho_s(\text{standard})} \quad (6)$$

i.e. $E_x = E_s(\rho_x/\rho_s)$. Where E_x is the radon gas exposure in unknown sample ($\text{Bq}/\text{m}^3 \cdot \text{day}$). ρ_x is the track density of unknown sample (tracks/ mm^2). Therefore, from the slope = ρ_s/E_s , E_x can be estimated as:

$$E_x = \rho_x / \text{Slope} \quad (7)$$

H. Determination of Radon Concentration

Radon concentration in surrounding air is measured in terms of Bq/m^3 , since the most regulate reference levels are specified in this unit. Determinations of radon concentration indoor buildings of the Department of Physics-College of Science are carried out by the following equation [16, 17]:

$$C_{\text{Rn}} (\text{Bq}/\text{m}^3) = \frac{E_x (\text{Bq} \cdot \text{day}/\text{m}^3) \left(\frac{\rho}{t}\right)}{\rho_x} \quad (8)$$

Where ρ is the track density (number of track / mm^2) of distributed detectors. t is the exposure time (days) of distributed detectors. Comparable method is also obtained for track detectors techniques to determine the calibration constant (factor). This is obtained by dividing

the track density by the total exposure of radon source. Then Eq. (8) of radon exposure becomes [18, 19]:

$$C(\text{Bq}/\text{m}^3) = \frac{1}{\text{slope}} \left(\frac{\rho}{t} \right)_{\text{det}} \quad (9)$$

Since

$$\frac{1}{\text{slope}} = \frac{E_s(\text{Bq}\cdot\text{d}/\text{m}^3)}{\rho_s(\text{track}/\text{mm}^2)}; \text{slope} = \frac{\rho_s(\text{track}/\text{mm}^2)}{E_s(\text{Bq}\cdot\text{d}/\text{m}^3)} \quad (10)$$

Where the slope is the calibration factor in terms of $(\text{track}\cdot\text{mm}^{-2}/\text{Bq}\cdot\text{day}\cdot\text{m}^3)$.

I. Dose Assessment Indoor Radon

A. The annual effective dose

The annual effective dose, H_E due to radon inhalation, which corresponds to the values of indoor air radon concentrations, was calculated according to the following expression [20]:

$$H_E = C_{Rn} \times E_q \times T \times 9n\text{Sv}(\text{Bq}\cdot\text{h}\cdot\text{m}^{-3})^{-1} \quad (11)$$

Where C_{Rn} is the average indoor air radon concentration, in Bq/m^3 . E_q is the indoor equilibrium factor between radon and its progeny ($=0.4$) (Wahl, 2007) [20]. T is the exposure time to this concentration, in hours, and $9n\text{Sv}(\text{Bq}\cdot\text{h}\cdot\text{m}^3)^{-1}$ is the dose conversion factor.

B. Potential Alpha Energy Concentration

The Potential Alpha Energy Concentration (PAEC) in terms of (WL) units was obtained using the relation [8, 21]:

$$\text{PAEC}(\text{WL}) = E_q \times C_{Rn}/3700 \quad (12)$$

C. Lung Cancer Cases per Year per Million Person

The lung cancer cases per year per million people (CPPP), was obtained using the relation [4, 21, 22]:

$$(\text{CPPP}) = H_E \times (18 \times 10^{-6} \text{mSv}^{-1}\cdot\text{y}) \quad (13)$$

Where $18 \times 10^{-6} \text{mSv}^{-1}\cdot\text{y}$ is conversion factor.

D. Alpha particles emitted of surfaces

Specific activities of various radionuclides, disintegrations per minute per 100 square centimetres ($\text{dpm}/100 \text{cm}^2$) used to measure alpha emitted of surfaces of an object, such as concrete or metal [23].

$$\text{Alpha emitted } (\text{Bq}/\text{cm}^2) = \text{dpm}/6000 \quad (14)$$

Where (dpm) is equal to $(\text{Bq}/60)$. Table 1 tabulated the location name and the cods at 1m and 1.75m in the department of chemistry laboratories building. While Fig. 6 shows the block diagram for the chemistry department laboratories building.

Table 1 Department of chemistry laboratories building.

Sequence	Location Name	Coding at 1m	Coding at 1.75m
1	Laboratory of Higher Studies Lab1	Ch1a2	Ch1a1
2	Library / Department of Chemistry	Ch2a2	Ch2a1
3	Teaching Staff Room No.1	Ch3a2	Ch3a1
4	Higher Studies Hall	Ch4a2	Ch4a1
5	Laboratory of Spectra2 G- LabA1	Ch5a2	Ch5a1
6	Teaching Staff Room No.2	Ch6a2	Ch6a1
7	Unit of Humanitarian Studies	Ch7a2	Ch7a1
8	Laboratory of Spectra1	Ch8a2	Ch8a1
9	Teaching Staff Room A1	Ch9a2	Ch9a1
10	Laboratory of Research of Inorganic	Ch10a2	Ch10a1
11	Laboratory of Prepare Diagnostic	Ch11a2	Ch11a1
12	Laboratory of Organic Chemistry	Ch12a2	Ch12a1
13	Laboratory of Organic Chemistry of Higher	Ch13a2	Ch13a1
14	Teaching Staff Room No.3	Ch14a2	Ch14a1
15	Laboratory of Analytical Chemistry	Ch15a2	Ch15a1
16	Inorganic Chemistry Laboratory LabA4	Ch16a2	Ch16a1
17	Inorganic Chemistry Laboratory for Higher	Ch17a2	Ch17a1
18	Laboratory of Physical Chemistry	Ch18a2	Ch18a1
19	Laboratory of Analytical Chemistry for	Ch19a2	Ch19a1
20	Laboratory of Industrial Chemistry for	Ch20a2	Ch20a1
21	Industrial Chemistry Laboratory	Ch21a2	Ch21a1
22	Laboratory of Analytical Chemistry LabA7	Ch22a2	Ch22a1
23	Laboratory of Research of Analytical	Ch23a2	Ch23a1
24	Laboratory Biochemistry	Ch24a2	Ch24a1
25	Laboratory of Biochemistry/Preparation	Ch25a2	Ch25a1
26	Physical Chemistry Laboratory for Students	Ch26a2	Ch26a1
27	Teaching Staff Room No.4	lost	lost
28	Teaching Staff Room No.5	lost	lost
29	Teaching Staff Room No.6	lost	lost

Note: a1=1m; a2=1.75m

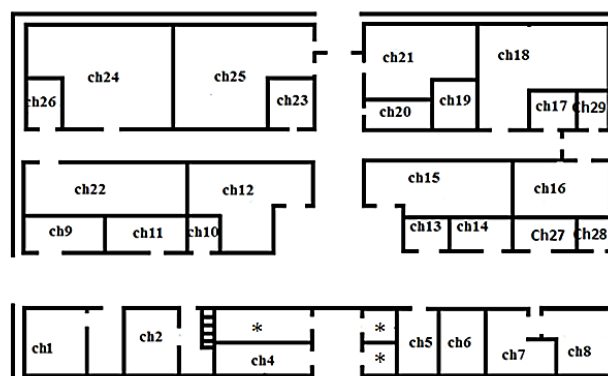

Fig. 6 Blockdiagram for the chemistry department.
* No suspended track.

III. RESULT AND DISCUSSION

Radon exposure for such long time is necessary in order to obtain relatively a good number of tracks and to be counting statistically. The calibration factor used for conversion of track density (track/mm².day) to radon concentrations in (Bq/m³) is 0.12423track.mm⁻² per Bq.day.m⁻³. The background has been calculated by calculating and subtracting from the track density of each track detector which was exposure to a period of measurement. The radiological risk associated with indoor radon exposure and relevant regulation has been evaluated. Regulations vary greatly between countries. The United States of America (USA) use a reference level of 148Bq/m³ for dwellings and 400Bq/m³ for workplaces (USEPA, 2004) [24]. The European Union (EU) accepts the recommended action level, the radiation level above which preventive action must be taken, included in the International Commission on Radiological Protection (ICRP, 1965) [25] of between 500 and 1500Bq/m³ given by Kavasi et al., 2006 [26], and ICRP, 2009 [27] has identified the limit of radon concentration for the population to be (200-300 Bq/m³) (ICRP, 2009) [27]. In the United Kingdom (UK) the Health and Safety Executive (HSE) given by Kendall et al., 2005 [28] has adopted a radon action level of 400Bq/m³ for workplaces. Also the limit is populated to be (148Bq/m³) in Environmental Protection Agency (EPA) (EPA, 2003) [29]. In Hungary the action level for workplaces is 1000Bq/m³ (Kendall et al., 2005) [28]. While Israel uses a reference level between 40 and 200Bq/m³ (Akerblom, 1999) [30]. There are no specific regulations in Iraq for indoor radon levels in either dwellings or workplaces. Department of Chemistry Building consists of several unites including laboratories preliminary studies and laboratories graduate addition to the private rooms of the masters. Among 68 suspended detectors, 6 have been lost. The results of the measurements at 1m and 1.75m for the department of chemistry are as follows:

A. Measurements at 1 meter for Department of Chemistry

Figs. 7, 8, 9, and 10 show the measured radon concentrations, the annual effective dose, potential alpha energy concentrations, and the lung cancer per year million person for different locations in the building of

department of chemistry at 1m. The minimum radon concentration is recorded at location (Ch16a1), inorganic chemistry laboratory lab A4, with a value 35.220±5.934Bq/m³, and the maximum value of radon concentration recorded at location (Ch3a1), teaching staff room no.1, with a value of 71.672±8.465Bq/m³, with an average value 49.129±7.009Bq/m³. The results are less than the limits (200-300Bq/m³) (ICRP, 2009) [27], and (148Bq/m³) (EPA, 2003) [29]. The measurements of radon concentrations from 30Bq/m³ to 40Bq/m³ are at locations: Ch16a1=35.219, Ch17a1=37.823, Ch21a1=39.741, Ch22a1=35.904, Ch23a1=37,412, Ch24a1=36.589 and Ch26a1=35.356Bq/m³. The measurements of radon concentrations from 40Bq/m³ to 50Bq/ m³ are at locations: Ch1a1=41.523, Ch8a1=41.797, Ch10a1=46.868, Ch11a1=46.045, Ch13a1=44.264, Ch14a1=47.553, Ch17a1=47.964 and Ch20=40.975. The measurements of radon concentrations from 50Bq/m³ to 60Bq/m³ are at locations: Ch4a1=59.612, Ch5a1=57.694, Ch6a1=57.009, Ch9a1=53.583, Ch18a1=57.968, Ch19a1=54.697. The measurements of radon concentrations from 60Bq/m³ to 70Bq/ m³ are at locations: Ch2a1=63.038, Ch7a1=61.257, Ch12a1=65.368 and Ch25a1=60.435. The measurements of radon concentrations from 70Bq/m³ to 80Bq/m³ are at location: Ch3a1=71.672. The values of the indoor annual effective dose vary from 0.370mSv/y in (Ch16a1) to 0.753mSv/y in (Ch3a1) with an average value 0.516mSv/y which is less than the lower limit of the admissible range 3-10mSv/y (ICRP, 1993)[31]. The values of the potential alpha energy concentration were found to vary from 3.808mWL in (Ch16a1) to 7.748mWL in (Ch3a1) with an average value 5.311mWL which is less than the admissible value 53.33 mWL given by UNSCEAR, 1993 [3]. The values of lung cancer cases per million person per year vary from 6.664 in (Ch16a1) to 13.565 in (Ch3a1) with an average value 9.296 per million person which is less than the lower limit of the admissible range 170- 230 per million person per year (ICRP, 1993) [31].

B. The measurements at 1.75 meter for Department of Chemistry

Figs. 11, 12, 13 and 14 show the measured radon concentrations, the annual effective dose, potential alpha energy concentrations, and the lung cancer per million

person per year for different locations in the department of chemistry building at 1.75m. The minimum radon concentration is recorded at location (Ch17a2), inorganic chemistry laboratory for higher studies A4, with a value $(31.793 \pm 5.638 \text{Bq/m}^3)$, and the maximum radon concentration recorded at location (Ch3a2), teaching staff room no.1, with a value of $68.246 \pm 2.46 \text{Bq/m}^3$, with an average value $45.487 \pm 6.768 \text{Bq/m}^3$. All results are within the worldwide limits $200\text{-}300 \text{Bq/m}^3$ (ICRP,2009)[27], and 148Bq/m^3 (EPA,2003)[29]. The measurement radon concentrations from 30Bq/m^3 to 40Bq/m^3 are at locations: Ch10a2=33.163, Ch11a2=33.026, Ch13a2=36.864, Ch14a2=35.904, Ch16a2=32,204, Ch17a2=31.793, Ch20a2=35.356, Ch21a2=37.960, Ch22a2=35.356, Ch23a2=36.864 and Ch26a2=36.041 Bq/m^3 . While the measurement radon concentrations from 40Bq/m^3 to 50Bq/m^3 are at locations: Ch1a2=45.634, Ch5a2=43.442, Ch9aa2=49.197, Ch15a2=44.127, Ch19a2=47.964, and Ch24a2=41.386 Bq/m^3 ; and the measurement radon concentrations from 50Bq/m^3 to 60Bq/m^3 are at locations: Ch2a2=55.090, Ch4a2=53.171, Ch7a2=53.034, and Ch25a2=55.364 Bq/m^3 . Then the measurement radon concentrations from 60Bq/m^3 to 70Bq/m^3 are at locations: Ch3a2=68.246, Ch6a2=67.698, Ch12a1=67.013 Bq/m^3 . Fig. 15 shows the radon concentrations at 1m and 1.75m for different locations in the laboratories building of the chemistry department. The minimum value recorded at location (Ch17a2) with a value of $31.793 \pm 5.638 \text{Bq/m}^3$ and the maximum value recorded at location (Ch3a1) with a value $71.673 \pm 8.466 \text{Bq/m}^3$. All results are within acceptable limits $200\text{-}300 \text{Bq/m}^3$ (ICRP, 2009) [27], and 148Bq/m^3 (EPA, 2003) [29]. The indoor annual effective dose varies from 0.334mSv/y in (Ch17a2) to 0.717mSv/y in (Ch3a2) with an average value 0.478mSv/y which is less than the lower limit of the admissible range $3\text{-}10 \text{mSv/y}$ (ICRP, 1993) [31]. The potential alpha energy concentration were found to vary from 3.437mWL in (Ch17a2) to 7.378mWL in (Ch3a2) with an average value 4.918mWL which is less than the admissible value 53.33mWL given by UNSCEAR, 1993 [3]. The lung cancer cases per million person per year vary from 6.016 in (Ch17a2) to 12.913 in (Ch3a2) with an average value 8.607 per million person per year which is less than the lower limit of the admissible range (170-230) per million person per year (ICRP,1993) [31].

C. Measurements of the Alpha particles emitted from wall surfaces

For this process, we need to use a filter paper which has specifically designed to take swabs from the surface of the walls inside rooms, since the walls consisting of building materials. The swabs have been taken from 52 swabs from the wall surfaces with squared area $(10 \times 10) \text{cm}^2$ by scanning all this area with a filter paper. The measurements have been done by insert the filter in the Ludlum3030 device for a period of one minute. This procedure will be repeated three times for each filter respectively, to take the average value then using Eq. (14) to calculate the emitted alpha particles. Fig. 16 shows the results of measurements of alpha particles emitted from the wall surfaces in the chemistry department building by using Ludlum3030. The minimum value is 0.000Bq/cm^2 recorded at locations (Ch5a2, and Ch17a2), laboratory of spectra2 G-Lab A1, and inorganic chemistry laboratory for higher students A4 respectively. The maximum value 0.02222Bq/cm^2 recorded at location Ch12a1 (the laboratory of organic chemistry) and Ch25a1 (the laboratory of biochemistry preparation room) respectively. The average value is 0.01154Bq/cm^2 for sitting position and 0.00983Bq/m^2 for standing position. Therefore, all results are lower than the recommended limit 0.04Bq/cm^2 given by Daniel, 2011 [32].

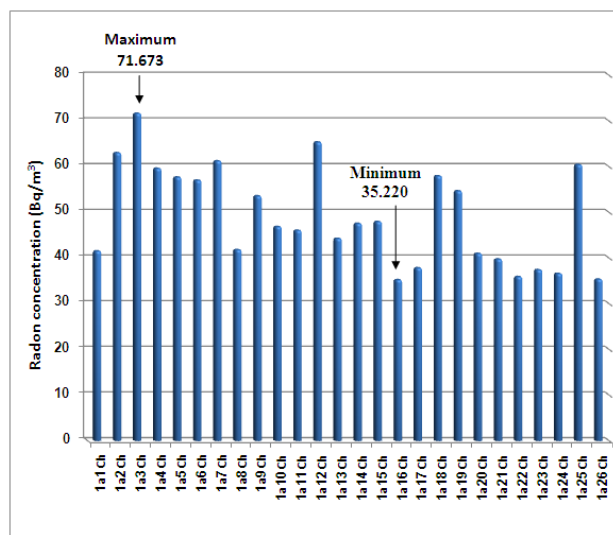

Fig. 7. Radon concentrations at 1m for different locations at department of chemistry.

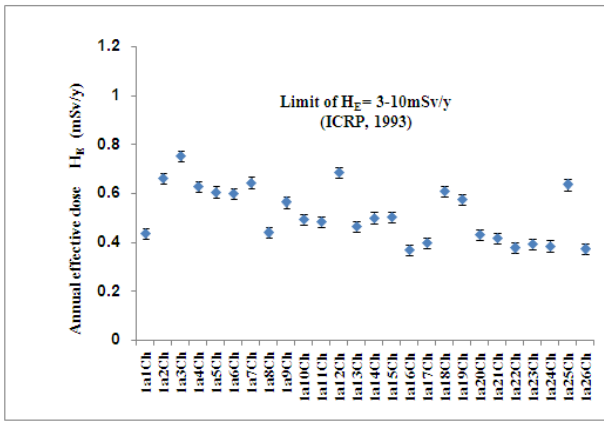

Fig. 8. Annual effective dose at 1m for different locations at department of chemistry.

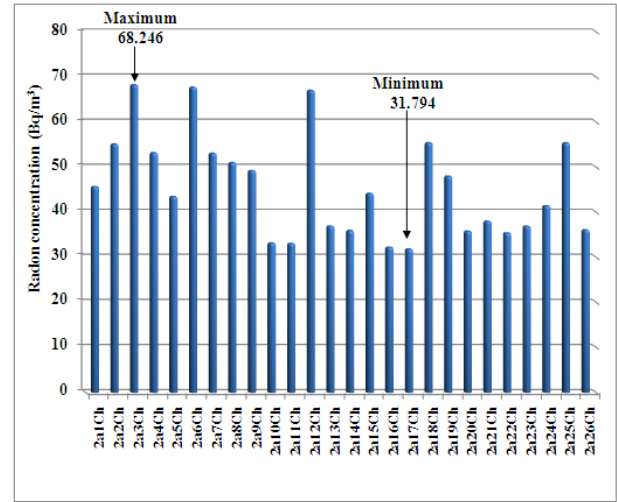

Fig. 11. Radon concentrations at 1.75m for different locations at department of chemistry.

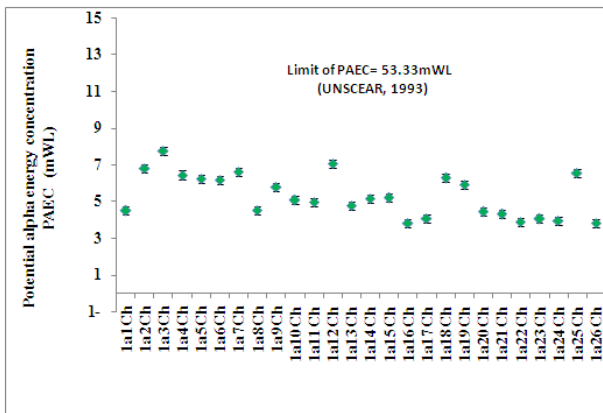

Fig. 9. Potential alpha energy concentration at 1m for different locations at department of chemistry.

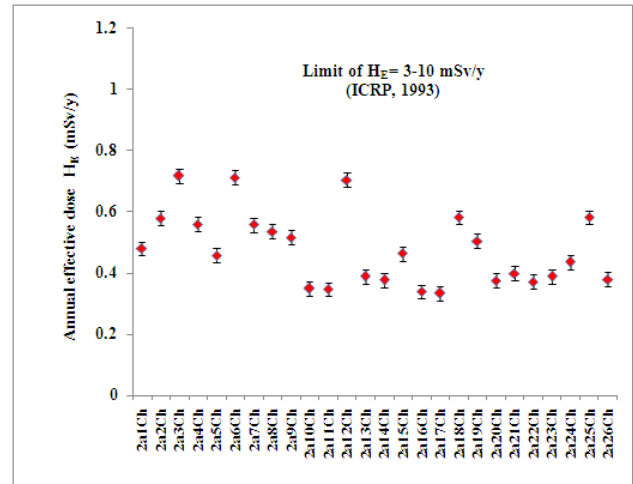

Fig. 12. Annual effective dose at 1.75m for different locations at department of chemistry.

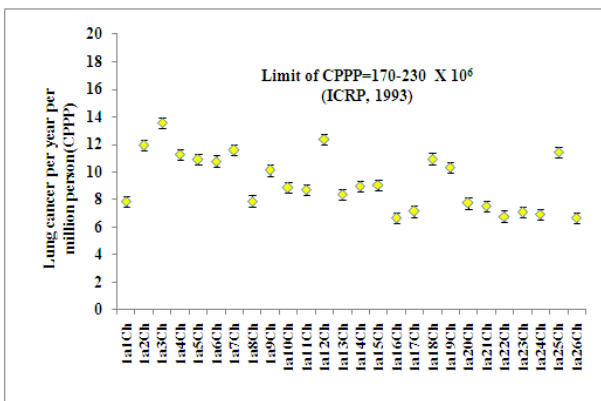

Fig. 10. Lung cancer cases per year per million person at 1m for different locations at department of chemistry.

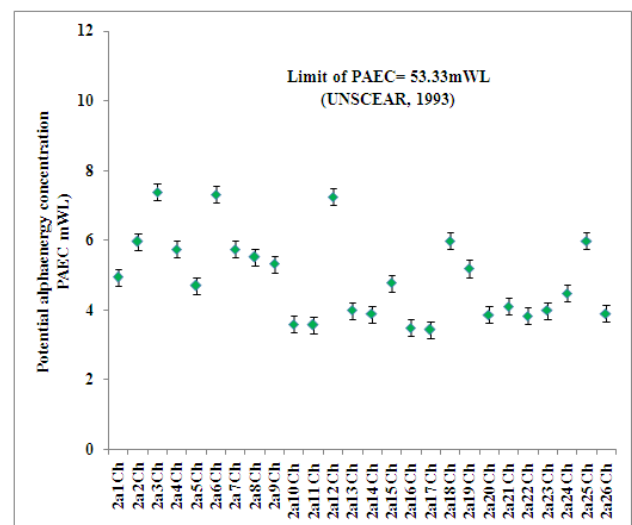

Fig. 13. Potential alpha energy concentration at 1.75m for different locations at department of chemistry.

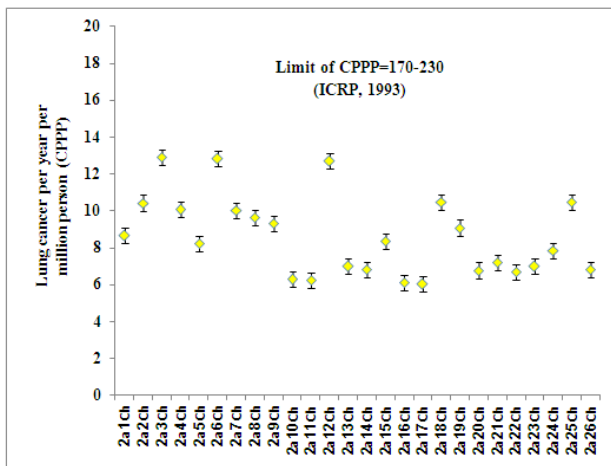

Fig. 14. Lung cancer cases per year per million person at 1.75m for different locations at department of chemistry.

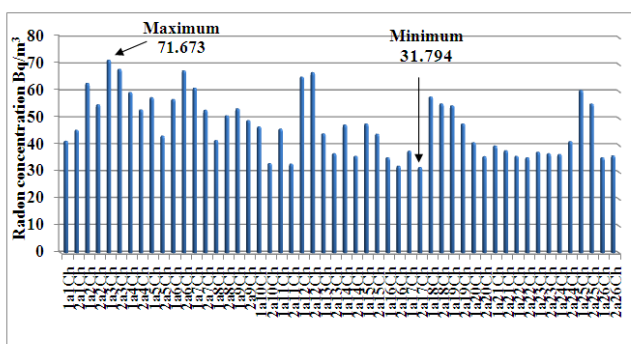

Fig. 15. Radon concentrations at 1m and 1.75m for different locations at department of chemistry.

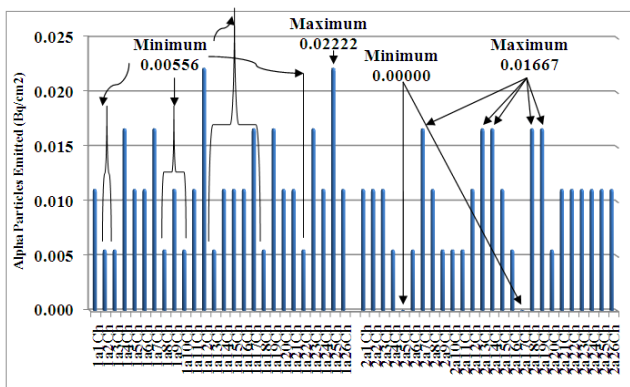

Fig. 16. Alpha particles emitted from surfaces in the department of chemistry at 1m and 1.75m.

IV. CONCLUSION

The maximum recorded value of higher radon concentrations in the laboratory building of Chemistry Department is $71.673 \pm 8.466 \text{ Bq/m}^3$ in (Ch12a2) the laboratory of organic chemistry, and the minimum value is $31.794 \pm 5.639 \text{ Bq/m}^3$ in (Ch17a2) the at inorganic chemistry laboratory for higher students A4 for standing

position respectively. Both results are lower than the recommended worldwide ($200\text{-}300 \text{ Bq/m}^3$) (ICRP, 2009), and (148 Bq/m^3) (EPA, 2003). The maximum indoor annual effective dose, potential alpha energy concentration, and lung cancer cases per million person per year are 0.704 mSv/y , 7.245 mWL , and 12.680 in (Ch12a2) the laboratory of organic chemistry for sitting position respectively. While the minimum values are 0.334 mSv/y , 3.437 mWL , and 6.016 in (Ch17a2) the inorganic chemistry laboratory for higher students A4 for standing position respectively. Which are less than the lower limit of the admissible limit range $3\text{-}10 \text{ mSv/y}$ (ICRP, 1993), 53.33 mWL given by (UNSCEAR, 1993), and the admissible limit range $170\text{-}230$ per million per person per year (ICRP, 1993). The maximum measured alpha particles emitted values from the wall surfaces are 0.02222 Bq/cm^2 at (Ch12a1, and Ch25a1) laboratory of organic chemistry and laboratory of biochemistry preparation room respectively for sitting position. The results are lower than the recommended worldwide limit (0.04 Bq/cm^2). All results are within the worldwide acceptable limits and there are no health risks.

V. REFERENCES

- [1] UNSCEAR, (2000), United Nations Scientific Committee on the Effects of Atomic Radiation, Sources and Effects of Ionizing Radiation, Report to the General Assembly with scientific Annex E: Occupational Radiation Exposures. Sources to Effects Assessment for Radon in Homes and Workplaces. New York, United Nations, 2000.
- [2] H. Cember and T. E., (2009), Johnson, Introduction to Health Physics, (4th edition) New York: Mc Graw-Hill Companies.
- [3] UNSCEAR, (1993), United Nations Scientific Committee on the Effect of Atomic Radiation. Sources and Effects of Ionizing Radiation, Report to the General Assembly with Scientific Annexes A and B: Exposures from natural sources of radiation; Exposures from man-made sources of radiation, New York, 1993.
- [4] H. H. Mansour, (2005), Measurement of Indoor Radon Level in Arbil Capital by Using Solid State Nuclear Track Detectors, Radiation Measurements, 40, pp.544-547.
- [5] K. N. Yu, D. Nikezic, F. M. F. Ng and J.K.C. Leung, (2005), Leung, Long – Term

- Measurements of Radon Progeny Concentrations with Solid State Nuclear Track Detectors, *Radiation Measurements*, 40, pp.560-568.
- [6] K.M. Abumurad and R. A. Al-Omari, (2008), Indoor Radon Levels in Irbid and Health Risks from Internal Dose, *Radiation Measurements*, 43, pp.S389-S391.
- [7] R., Shweikani, (2012), Variatio of Radon Exposure in Damasus Dwelling, *Applies Radiation and Isotopes*, 70, pp.785-789.
- [8] S. Kansal, R. Mehra and N. P. Singh, (2012), Life Time Fatality Risk Assessment Due to Variation of Indoor Radon Concentration in Dwellings in Western Haryana, India, *Applied Radiation and Isotopes*, 70(7), pp.1110-1112.
- [9] S.S. Al-Ghamdi, (2014), Seasonal and Location Dependence of Indoor and Soil Radon Concentrations in Two Villages Najran Region, Saudi Arabia, *Radiation Measurements*, 69, pp.12-17.
- [10] A. Sakoda, O. Meisenberg and J. Tschiersch, (2015), Behavior of Radon Progeny Produced in a Scintillation Cell in the Flow – Through Condition, *Radiation Measurements*, 77, pp.41-45.
- [11] A. D. Saeed and I. Radomir, (1997), Radon Measurements by Etched Track Detectors: Applications in Radiation Protection, Earth Sciences and the Environment, Published by World Scientific Publishing Co.Inc , May 1997. Edited by: A. D. Saeed, (University of Birmingham, England) and I. Radomir, (University of Ljubljana and University of Maribor, Slovenia, 1997).
- [12] O. Amalds, N. H. Custball and G. A. Nielsen, (1989), Cs-137 in Montarq Soils, *Health Physics*, 57(6), pp.955-958.
- [13] E. H. EL-Araby, (2013), Environmental Air Dosimetry in Some Locations of Jazan Using Passive Track Detectors, *Life Sciences and Technologies*, 1(1), pp.75-78.
- [14] F. Michael, (2007), *Radioactivity: Introduction and History*, 1st edition, Elsevier.
- [15] J. Chen, NM. Rahman and IA. Atiya, (2010), Radon Exhalation from Building Materials for Decorative Use, *Environmental Radioactivity*, 101(4), pp.317-322.
- [16] A. B. Tanner, (1980), Radon Migration in the Ground: a Supplementary Review. In Gessell, TF, and Lowder, WM, (eds.), *Natural Radiation Environment III*. Report No. CONF - 780422, Springfield, VA: National Technical Information Service, 1980, pp.5-56.
- [17] M. Al-Kofahi, B. Khader, A. Lehlooh, M. Kullab, K. Abumurad and B. Al-Bataina, (1992), Measurement of Radon 222 in Jordanian Dwellings, *Nuclear Tracks Radiation Measurements*, 20, pp.377-382.
- [18] J. Wiegand, (2001), A Guideline for the Evaluation of the Soil Radon Potential Based on Geogenic and Anthropogenic Parameters, *Environmental Geology*, 40, pp.949-963.
- [19] M. Rasas, (2003), Measurement of Radon and Its Daughter's Concentrations in Indoor and Outdoor Throughout Gaza Strip", M.Sc. Thesis. Islamic University of Gaza.
- [20] W. Wahl, (2007), Radionuclide Handbook for Laborator Workers: in Spectrometry, Radiation Protection and Medicine, ISuS, Germany.
- [21] A. H. Ismail and M. S. Jaafar, (2010), Indoor Radon Concentration and Its Health Risks in Selected Locations in Iraqi Kurdistan Using CR-39 NTDs. The 4th International Conference on Bioinformatics and Biomedical Engineering (ICBBE 2010). 18-20 June 2010. Cheengdu-China.
- [22] A. A. Abdullah, (2013), Internal and External Radiation Exposure Evaluation amongst Selected Workers and Locations in Iraq". Ph.D. Thesis, University Sains Malaysia, Malaysia.
- [23] OSA, Office for Research Safety, (2010), *Radiation Safety Handbook. Radiation Worker Registratio and Personnel Dosimetry. Dose and Exposure, Dose Equivalent*. Northwestern University.
- [24] USEPA, US EPA, Environments Division (6609J), (2004), A Citizen's Guide to Radon: The Guide to Protecting Yourself and Your Family from Radon (Washington, DC 20460 US EPA 402-K-02-006, 2004.
- [25] ICRP, (1965), International Commission on Radiological Protection. Recommendations of the International Commission on Radiological Protection, *Annals of the ICRP/ICRP Publication*, 9, pp.1-27.

- [26] N. Kavasi, T. Kovacs, C. Nemeth, T. Szabo, Z. Gorjanacz, A. Varhegyi, J. Hakl and J. Somlai, (2006), Difficulties in Radon Measurements at Workplaces, *Radiation Measurements*, 41, pp.229-234.
- [27] ICRP, (2009), International Commission on Radiological Protection, International Commission on Radiological Protection Statement on Radon. ICRP, Ref.00/902/09,2009.
- [28] G.M. Kendall, B.M.R. Green, J.C.H. Miles and D.W. Dixon, (2005), The Development of the UK Radon Programme, *Radiological Protection*, 25(4), p.475.
- [29] EPA, Environmental Protection Agency, (2003), Assessment of Risks from Radon in Homes, (EPA 402-R-03-003). Office of Radiation and Indoor Air United States Environmental Protection Agency, Washington, DC, 20460, 2003.
- [30] G. Akerblom, (1999), Radon legislation and National Guidelines Swedish Radiation Protection Institute, SSI Report 99:18, ISSN 0282-4434, 1999.
- [31] ICRP, (1993), International Commission on Radiological Protection. Against Radon-222 at Home and at Work, ICRP Publication 65, Annual of the ICRP Pergamon. 23(2), 1993.
- [32] A. G. Daniel, (2011), Basic Radiation Protection Technology, 6th edition, Publisher: Pacific Radiation Corporation, ISBN: 978-0-916339-14-2, 2011.