

# State of the Art of Solar Absorption Cooling Technologies

Sabah Auda Abdul Ameer<sup>1</sup>, Haroun A. K Shahad<sup>2</sup>

<sup>1,2</sup>Mechanical Engineering Department University of Babylon Babylon-Iraq

**Abstract:** This study includes a comprehensive review of researches related to solar absorption cooling technology. Parameters that affect their performance are likewise talked about. Their properties, designs and mathematical formulation are mentioned. Many designs have been set for absorption chiller. Absorption chillers can be classified to single effect cycle, double effect cycle, half effect cycle and Gax cycle. The solar collector is the main component of energy collection in absorption cooling technologies.

**Keywords:** Absorption system; solar cooling; solar absorption chiller.

## I. ABSORPTION

Invention of absorption refrigeration machine is attributed to Edmond Carré, who built a water-sulfuric acid machine in 1850 Niebergall, [1]. His machine was also used in the first solar cooling machine demonstrated by Augustin Mouchot at the Paris World Exhibition in 1878 Thévenot, [2]. The solar cooling technique usually use absorption refrigeration for several reasons. First of all, it requires no or very low electric power. A famous example is the heat-driven ammonia diffusion refrigerator manufactured by Electrolux for the first time in 1925 based on Swedish students, Carl G. Munters and Baltzar von Platen. The machine worked very quietly and completely without electricity. It had been distributed to millions of homes worldwide until 1950s. This type of refrigerator is still being produced for hotel mini-bars and caravans. Another example is a self-circulating LiBr-water chiller, the concept of which was originally suggested by Edmund AltenkirchStephan [3]. This system has no moving parts as illustrated in Fig. 1.

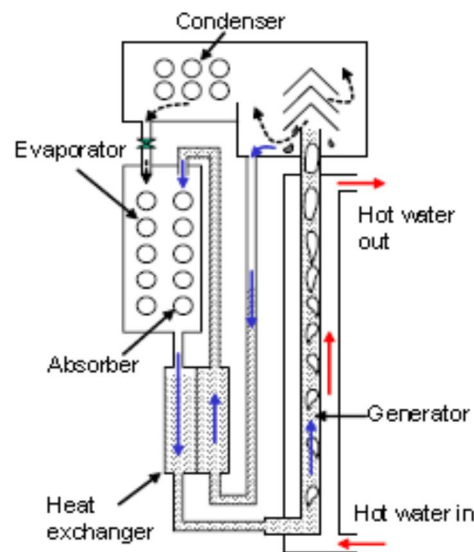

Fig. 1. Self-Circulating LiBr-Water Absorption Chiller [54]

LiBr solution is supplied from an absorber to the bottom of the generator by gravity, where it is heated by hot water. The solution boils and is driven upwards by the buoyancy of the generated steam bubbles. At the top of the generator, the heavy solution is separated from the steam and flows further to an absorber at a high position. From the bottom of the absorber, the solution flows back to the generator.

Yazaki Energy Systems Inc[4], a Japanese manufacturer, produced such a self-circulating LiBr-water chiller with 35 kW cooling capacity, which consumes only 210 W of electricity for chilled water circulation.

## International Journal for Research in Applied Science & Engineering Technology (IJRASET)

Secondly, for the same capacity, the physical dimension of a liquid absorption machine is smaller than for solid sorption machines due to the high heat transfer coefficient of the liquid sorbent, i.e. absorbent. Besides, the fluidity of the absorbent gives more flexibility in realizing a more compact and/or efficient machine.

Finally and perhaps the most importantly, because absorption refrigeration had already established its position in refrigeration industry, the well-developed sorption community supported its application in solar cooling by providing expertise in operation and manufacturing.

Single-effect LiBr-water chiller is widely used in solar energy for cooling applications.

A research group started a series of researches on solar absorption cooling by designing and optimizing solar heating and cooling systems for several locations Lof and Tybout, [5]. One of their conclusions was that a combined heating and cooling system was more economical than a heating alone system in most locations. A solar house with a combined cooling and heating system based on a single-effect LiBr-water chiller was investigated in a university campus Ward and Lof[6]; Ward et al, [7].

Hattem and Dato [8] setup a solar absorption cooling system at EU Joint Research Center in Ispra, Italy, which consisted of a 4.6 kW LiBr-water chiller and 36 m<sup>2</sup> flat plate collectors. They reported theoretical and experimental results were in good agreement and the measured seasonal average of the chiller COP and the overall cooling efficiency were 0.54 and 9.6% respectively.

Al-Karaghoul et al [9] recorded the operation results of a solar cooling system installed at the Solar Energy Research Center in Iraq, which was considered the largest solar cooling system at the time. The system was equipped with two 60 ton LiBr-water chillers, 1577 evacuated tube collectors and various backup systems. They reported daily average collector efficiency of 49%, chiller COP 0.62 and solar fraction of 60.4%.

Best and Ortega [10] summarized the results of Sonntlan Mexicali Solar Cooling Project from 1983 to 1986 in Mexico. The solar cooling system included six single-family houses, 316 m<sup>2</sup> flat plate collectors, 30 m<sup>3</sup> heat storage, a 90 kW ARKLA-WFB 300 So-laire LiBr-water chiller and a 200 kW cooling tower. After a series of improvements on the solar collector system, the system managed to deliver enough cooling power that improved the yearly solar fraction up to 75%. COP of the absorption chiller varied from 0.53 to 0.73 when hot water was provided at the temperatures between 75 to 95 °C.

Izquierdo et al [11] reported the performance of a LiBr-water chiller with 35 kW nominal cooling capacity driven by hot water from 49.9 m<sup>2</sup> flat plate collectors installed at a typical Spanish house in Madrid. Since the solar system was originally designed for 10 kW cooling capacity, the absorption chiller operated far away from its nominal working condition and yielded the maximum cooling capacity of only 7.5 kW at the average COP of 0.34. Due to lack of small-capacity LiBr chillers (<35 kW) in the market, some small single-effect LiBr-water chillers have been developed recently and are currently under field test.

Storkenmaier et al [12] reported the development of a 10 kW water-cooled single-effect LiBr-water chiller. The machine was capable of producing 15°C chilled water from 85°C hot water with the COP of 0.74 being cooled by cooling water at 27°C. The design chilled water temperature was set rather high at 15°C for the use of chilled ceilings. The cooling capacity was reported to vary between 40 to 160% of the nominal capacity with the hot water temperature increasing from 56 to 105°C.

Safarik et al [13] presented the performance data of a recently developed water-cooled single-effect LiBr-water chiller. The machine produced about 16 kW cooling at 15°C at the COP 0.75 with 90°C hot water and 32°C cooling water. With 27°C cooling water, COP increased to 0.8 and 80°C hot water was enough to produce the same cooling capacity.

Double-effect LiBr-water machines were also used in a few solar cooling projects. Due to the requirement of a high driving temperature (150°C), in most cases, the hot water from solar collectors was fed to the low-temperature generator of a double-effect machine (Ishibashi, [14]; Lamp and Ziegler, [15]). This system has a merit of alternatively operating the system in a single-effect cycle with solar heat or in a double-effect cycle with the heat from fuel combustion so that it can achieve a high seasonal efficiency.

Lokurlu and Müller [16] reported a system installed at a hotel in Turkey, which consisted of a steam-driven double-effect machine, a trough type parabolic solar collector and a backup steam boiler. The trough collector with 180 m<sup>2</sup> aperture area heated pressurized water up to 180°C and this water in turn generated 144°C steam (4 bar) for a 140 kW double-effect LiBr-water chiller.

Ammonia absorption machines have also been popular. Although not as popular as LiBr machines, they have been used for various applications, mostly where a LiBr-water machine was not deemed suitable, e.g. refrigeration, air-cooled or heat pump operation.

Several studies were reported of the solar intermittent ammonia absorption refrigerators (Trombe and Foex, [17]; Chinnappa, [18]; Paassen, [19]). An intermittent ammonia absorption cycle can make an effective solar refrigerator that would be particularly appreciated in developing countries because it requires no power other than heat and guarantees a long life without any trouble. But in this application, absorption technology seems to have been overwhelmed by the adsorption counterpart. Hardly any study on an intermittent absorption refrigerator has been reported since early 1990.

## International Journal for Research in Applied Science & Engineering Technology (IJRASET)

The ammonia diffusion cycle of the early heat-driven domestic refrigerators has also found its place in solar cooling. Because the diffusion cycle needs no moving part, it makes a fully autonomous system when combined with solar collectors (Gutiérrez, [20]; Kunze, [21] Jakob et al, [22]). According to Jakob et al [22], recent development activities on solar DAR (Diffusion Absorption Refrigerator) in Europe cover cooling capacities between 16 W and 2.5 kW and cycle COPs between 0.2 and 0.5.

For development of continuous solar-driven refrigerators or heat pumps, single-effect ammonia machines have been the most frequently considered (Shiran et al, [23]; McLinden and Klein, [24]; Alvares and Trepp, [25]; Best, [26]; ARTISC, [27]).

Ammonia absorption refrigeration system had been demonstrated at a winery in Graz, Austria (SACE Evaluation report, [28]). The system consists of a 10 kW water-cooled ammonia water absorption chiller, 100 m<sup>2</sup> flat collectors and a 40 kW wood chip boiler as a backup heater. The system was designed to maintain a wine storage at 10 to 12°C.

Richter and Safarik, [29] introduced two small solar-driven water-cooled ammonia absorption cooling plants operating in Germany. One air conditioning system produced 15 kW cooling at 3°C driven by 95°C hot water and the other produced 20 kW at -6°C driven by hot water at 100°C. In both cases, COP was about 0.54.

Other than introduced above, numerous studies have been reported including various absorption cycles (Chinnappa and Martin, [30]; Sofrata et al, [31]; Alizadeh, [32]; Göktun and Er, [33]) and different working pairs (Sawada et al, [34]; Romero et al, [35]; Arivazhagan et al, [36]) and so on.

### II. EVALUATION OF SOLAR ABSORPTION COOLING SYSTEMS

From the variety of solar collectors and absorption chillers, various solar absorption cooling systems can be considered for solar air conditioning. Although, in principle, all of them may serve for the same purpose, they will not be equal in energetic and financial performance. A system must be thoroughly evaluated before final selection. Evaluation of a solar cooling system is generally not easy because there are many parameters to consider, most of which are time-dependent. The evaluation criterion is, however, simple. The best system must be the one that would bring the maximum benefit out of the minimum investment. For a fair evaluation, different systems should be compared in a common realistic environment. Dynamic simulation would be one of such environments. Prediction of dynamic performance is particularly important for solar thermal systems considering the fact that solar energy is transient in nature and economics of a solar system is critically dependent on its effective use. Therefore dynamic simulation has been an indispensable part of many research works where various solar thermal systems were evaluated.

The literature survey of Zhuo [37] on the previous works on dynamic modeling of absorption systems revealed that early works were focused on the performance of whole solar cooling systems using quasi-steady state models (Stuart and Sheridan, [38]; Anand et al, [39]; McLinden and Klein, [24]; Kaushik et al, [40]; Alvares and Trepp, [41]). In these works, only storage tanks were modeled with differential equations and other components were modeled with steady state equations, which was typically the adopted approach in TRNSYS. Zhuo [37] also classified the previous works into two groups depending on the details of the model, i.e. lumped and distributed parameter models, and pointed out that most of the works were based on lumped parameter models with two exceptions (Butz and Stephan, [42]; Sano et al, [43]).

Some other works not mentioned in Zhuo [37] included modeling of a periodically operating ammonia-water heat pump by Jeong, [44], a solar ammonia-water absorption cooling system with refrigerant storage by Kaushik et al, [45] and more recent works on hot water-driven LiBr-water absorption heat pump and chillers by Jeong et al, [46]; Bina et al, [47]; Kohlenbach and Ziegler, [48]; Fu et al, [49].

Distributed parameter model such as Butz and Stephan [50] required excessive computing time for the time scale to be simulated in the present study. For comparison of different systems in terms of seasonal performance, lumped parameter model was thought sufficient and models were developed accordingly. The present approach is different from others in the aspect that while most of the previous works assumed equilibrium between bulk working fluids, the absorption chiller models in this study were developed to take account of the influences of non-equilibrium conditions by considering finite mass transfer rates in sorption processes.

Another aspect worth mentioning about the present work is that a “modular” approach has been taken when modeling a system. This approach has been preferred considering the large number of absorption chillers and working fluids to be modeled for the present purpose. Writing an individual program for each of different systems is a time-consuming and redundant job especially when those systems are only different combinations of common components. In the present study, the “common components” were developed in a flexible way so that they can be shared among different systems. In this respect, the approach taken by this study is similar to

## International Journal for Research in Applied Science & Engineering Technology (IJRASET)

that of Fu et al [49].

### A. Basic Components in Solar Absorption Cooling

Solar absorption cooling systems which consist of two basic components, solar collector and absorption chiller, are discussed below to give an overview of the state of the art of solar absorption cooling technology.

1) *Solar Collector*: Currently, several types of solar collector are available in the market ranging from a simple unglazed plastic solar collector for swimming pools to a sophisticated evacuated tube collector that could even be used for the production of high- temperature steam. Collector Catalogue [51], published by Institute für Solartechnik SPF at Rapperswil in Switzerland, provides information about 209 solar collectors from 120 companies active in the European market. Although there are many other parameters that determine the characteristics of a solar collector, two values are of particular interest to system designers, namely efficiency and price.

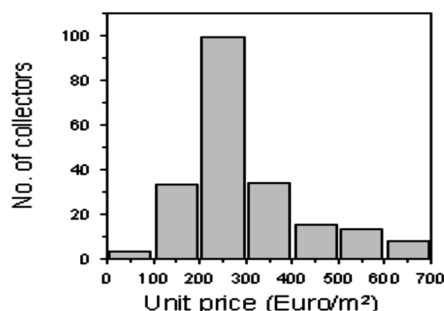

Fig. 2 Price of Solar Collectors in European Market [54]

Fig. 2 shows the price distribution of the solar collectors listed in the catalogue. In the figure, it is clearly shown that most of the collectors are in the price range from 200 to 300 Euro/m<sup>2</sup>.

Regarding the type of a solar collector, most of collectors below 400 Euro/m<sup>2</sup> are flat plate collectors and the others are evacuated tube collectors with or without optical concentrators. The efficiency values of the solar collector are rather scattered. Large deviations in efficiency are found between the solar collectors with comparable prices. Therefore any absolute price from the catalogue cannot be used with high reliability. Only the general trend of efficiency against the price could be extracted from the catalogue. Static efficiency of a solar collector, which was previously defined is commonly described by Eq. (1).

$$\eta_{col} \equiv \frac{\dot{Q}_{col}}{I_p \times A_{col}} = \eta_o - c_1 T_r - c_2 T_r^2 I_p \quad \text{where } T_r \equiv (T_{htm,avg} - T_{amb})/I_p \quad (1)$$

The reduced temperature,  $T_r$  is the temperature difference between the heat transfer medium in the solar collector and the ambient air divided by the solar radiation, which can be considered as the driving potential of the solar collector's heat loss to the ambient.

The first term  $\eta_o$  on the right side of Eq. (1) represents the optical efficiency of a solar collector. The second term gives the combined conductive and convective heat losses. The last term can be understood as a correction term to represent the non-linear characteristic of a solar collector in high operating temperature range due to radiation heat loss. Among the three constants  $\eta_o$ ,  $c_1$  and  $c_2$ , only  $c_1$  is subject to change in the presence of wind. Collector Catalogue [51] provides these constants for many solar collectors under standard test conditions. Fig. 3 shows these constants against the solar collector price.

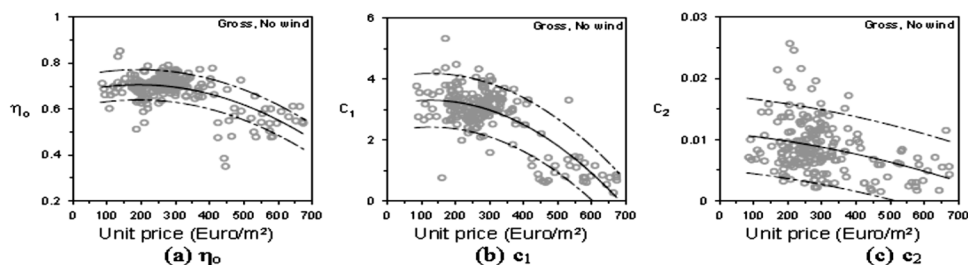

Fig. 3 Variation of the Constants in Eq. (1) Against the Collector

## International Journal for Research in Applied Science & Engineering Technology (IJRASET)

The data in Fig. 3 are based on the gross efficiency of a solar collector.  $A_{col}$  in Eq. (1) is the gross surface area, measured under no wind condition. Although  $c_2$  has the least influence on the efficiency among the three constants, it is not negligible when the working temperature is high.

In Fig. 3a, the maximum optical efficiency is as high as 0.8 for the collectors in the low price range but it is only 0.6 for those in the high price range. Since this  $\eta_0$  is not based on the absorber surface area but on the gross surface area of a collector, this does not mean that more expensive collectors have poorer optical performance but means that expensive solar collectors like evacuated tube type collectors have a relatively small absorber surface area within the same gross dimension.

A large amount of heat can be lost from a solar collector via conduction and convection to ambient depending on its insulation. And this insulation performance varies widely with collector price, which is shown in terms of the coefficient  $c_1$  in Fig. 3b. A good evacuated solar collector has a very small  $c_1$ , several times smaller than that of a cheap flat plate collector.

Using the data in Fig. 3, the constants in Eq. (1) are described as a function of the collector price by,

$$\eta_0 = 0.671 (\pm 0.066) + 3.565 \times 10^{-4} \omega - 9.266 \times 10^{-7} \omega^2 \quad (2A)$$

$$c_1 = 3.971 (\pm 0.88) - 1.665 \times 10^{-3} \omega + 5.695 \times 10^{-6} \omega^2 \quad (2B)$$

$$c_2 = 1.182 (\pm 0.61) \times 10^{-2} - 6.572 \times 10^{-6} \omega + 7.684 \times 10^{-9} \omega^2 \quad (2C)$$

Where  $\omega$  is the unit collector price in Euro/m<sup>2</sup> of gross area. The values between parentheses are standard deviations, which are also shown as dotted lines in Fig. 3. Using Eqs. (1) and (2), efficiency curves are shown for some differently priced collectors in Fig. 4.

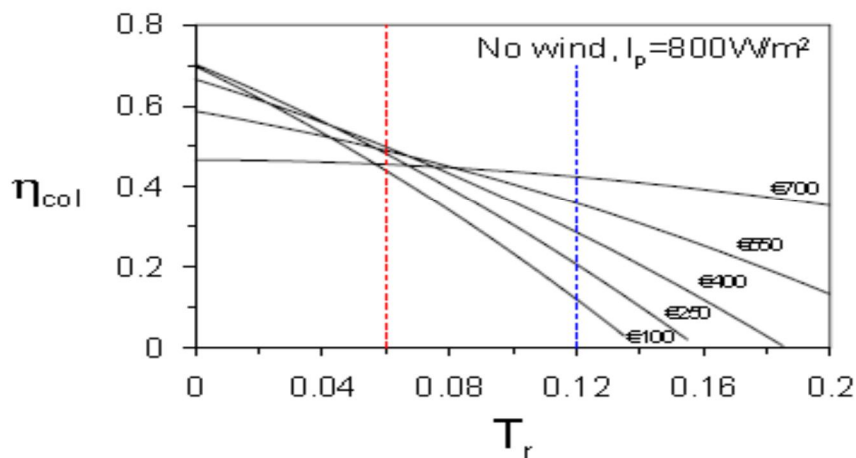

Fig.4 Collector Efficiency vs. Reduced Temperature With Collector Price as Parameter [54]

It can be seen from Fig. 4 that efficiencies of different solar collectors are not much different at around  $T_r = 0.06$ . The maximum deviation between the different efficiency values is only 6% at this point (i.e.  $44 \leq \eta_{col} \leq 50\%$ ). This means that, when the ambient temperature is 32°C and the solar intensity is 800 W/m<sup>2</sup>, all solar collectors can produce 80°C hot water within the efficiency range of  $47 \pm 3\%$  regardless of the price.

Fig. 4 also shows that expensive collectors like evacuated tube type collectors outperform flat plate collectors only when  $T_r$  is large, i.e. when either the working temperature is high or the intensity of solar radiation is low.

Eqs. (1) and (2) can be used to represent the performance-price characteristics of a typical solar collector available in the European market, which can be used as a common platform for the evaluation of different solar cooling systems.

2) *Absorption Chiller*: Absorption chiller is the largest portion in market taken by direct-fired machines with capacities larger than, at least, 35 kW. Recent R&D effort in the field of direct-fired machines is mainly focused on the development of high efficiency machines by raising the working temperature (Garimella et al, [52]; Stitou et al, [53]) or hybridization (Kim et al, [54];

## International Journal for Research in Applied Science & Engineering Technology (IJRASET)

Worek et al, 2003[55]) of absorption cycles.

On the other hand, the market for indirect-fired chillers, i.e. water- or steam-fired machines, is relatively small and much of recent R&D activities are focused on the development of absorption chillers for small-scale residential and commercial applications.

Table 1 Small-capacity absorption chillers (cooling capacity smaller than 35 kW) [54]

Cycle type	Working pair	Manufacturer	Country	Q <sub>e</sub> (kW)	Cooling medium	Heating medium	Min. driving T(°C)	Cooling COP <sup>5</sup>
SE <sup>1</sup>	LiBr-H <sub>2</sub> O	Phoenix	Germany	10	water	Hotwater	90-100	0.74
		EAW	Germany	15				0.7
		Yazaki	Japan	35				0.71
		Rotartica	Spain	11				0.67
	LiCl-H <sub>2</sub> O	ClimateWell AB	Sweden	7				0.7
	NH <sub>3</sub> -H <sub>2</sub> O	Pink	Austria	10				0.6
DE <sup>2</sup>	LiBr-H <sub>2</sub> O	Rinnai	Japan	5	water	Gas-fired	150-170 <sup>4</sup>	1.2-1.3
GAX <sup>3</sup>	NH <sub>3</sub> -H <sub>2</sub> O	Robur	Italy	18	air		160-180 <sup>4</sup>	0.8-0.9
		Cooling technologies	USA	17				

SE: Single-Effect absorption cycle; 2. DE: Double-Effect absorption cycle; 3. GAX: Generator Absorber eXchange absorption cycle; 4. Equivalent steam or hot water temperatures; 5. Estimated cooling COP based on net heat input to the system

Among the chillers shown in Table 1, only the single-effect chillers are suitable for solar cooling. The particular double-effect and GAX chillers are all direct-fired. Nevertheless they can also be made steam- or water-fired and their minimum driving temperatures in Table 1 are the equivalent steam or hot water temperatures in that case.

Currently, all single-effect absorption chillers in the market are water-cooled and they require a driving temperature in the range between 90 and 100°C for a COP between 0.6 and 0.74. No indirect-fired double-effect chiller has been reported in this small capacity range.

The particular double-effect chiller in the table is a water-cooled, city gas-fired machine and yields a cooling COP of about 1.2. It would require approximately 160°C steam or pressurized hot water to drive an equivalent indirect-fired machine.

The GAX chiller is another high-efficiency option but none is currently available for solar cooling in the market. Both GAX chillers in the table are air-cooled gas-fired machines mainly used in large houses or in small commercial buildings. Cooling COP is about 0.8 and it would require approximately 170°C steam or pressurized hot water to drive an equivalent indirect-fired machine.

Until now, virtually all absorption chillers use either water or ammonia as a refrigerant. In general, a water absorption chiller yields higher COP than an ammonia chiller at the same driving temperature. This is because the latent heat of water is larger than of ammonia and thus requires less circulation of the absorbent in the absorption cycle. But water absorption cycles are not without shortcomings. Due to the risk of crystallization of absorbents, no air cooled water absorption chiller has been successfully developed until now. Besides, there is also no water absorption refrigerator because water freezes at 0°C. These are the applications where ammonia chillers are dominating. Although its COP is lower, an ammonia chiller can be made for refrigeration and for air-cooled operation.

Currently, in the field of solar absorption cooling, water-cooled single-effect chillers are dominant. The reason becomes clear when the driving temperature is considered. The driving temperature of a single-effect water-cooled absorption chiller is between 90-100 °C in Table 1, which is close to but below the boiling temperature of water. Then the driving temperature of an air-cooled single-effect absorption chiller would certainly be beyond 100°C not to mention the other types of high-temperature absorption chillers. An absorption chiller with a driving temperature higher than 100°C is unfavorable for some reasons. Firstly, it needs expensive high-temperature solar collectors. Secondly, the whole solar collector circuit (piping, storage, pumps, valves and etc.) needs to be pressurized to prevent water from boiling unless it uses less volatile heat transfer media like glycol solutions or oils at the expense of

## International Journal for Research in Applied Science & Engineering Technology (IJRASET)

high auxiliary power consumption and environmental disfavor. Nevertheless, because a high temperature chiller has a potential to compensate for these disadvantages with better performance, use of a high-temperature chiller should not be abandoned without a proper analysis.

Disadvantages of water-cooled systems have also to be pointed out. A water-cooled system is inevitably accompanied by high initial and operation costs concerning the use of a cooling tower. And besides, the open water network becomes an ideal place for the growths of bacteria that could cause various diseases.

Regarding the initial cost of a water-cooled system, for example, a cooling tower for 10 kW cooling capacity alone costs approximately €2,000-2,500 (Schweigler et al, [56]), which is €200-250 per kWcooling. This is a substantial figure considering that a single-effect LiBr-water absorption chiller costs €400~1,000 per kWcooling depending on capacity (Arsenal Research, 2005). That is, the cost of a cooling tower alone is expected to be as much as 20-25% of an absorption chiller.

Water consumption is also not negligible. According to a recent survey of European solar cooling systems (SACE, 2003), the average water consumption of water-cooled solar cooling systems in Europe is 5.3 kg/kWh cooling. This is a huge waste considering that the evaporation of only 1.4 kg water is enough to provide an equivalent cooling effect.

Although a cooling tower may be the only practical solution for high-intensity applications like multi-storey office buildings and hotels, it is not desirable for less demanding applications like medium-size houses or small offices, which small absorption chillers are aiming at.

Various solar absorption cooling systems will be evaluated in the following sections in view of all the aspects discussed above. Before proceeding further, the working principles of various absorption cycles are briefly explained in the following subsections.

### B. Types of Absorption Cooling Cycles

1) *Single-Effect Cycle:* The single-effect (SE) cycle is the simplest absorption cycle, having only a minimum number of components. The biggest advantage of the SE cycle is its simplicity. As is shown in Fig. 4, a SE chiller consists of five main components, namely generator (GEN), absorber (ABS), condenser (CON), evaporator (EVA) and a solution heat exchanger (SHX). **Kim et al, [54]**

Heat recovery is realized only by a single-phase solution heat exchanger (SHX) located between generator and absorber. For systems where it is acceptable, another single-phase refrigerant heat exchanger (RHX) can also be used between the liquefied refrigerant from condenser and the refrigerant vapor from evaporator to increase the sub cooling of liquefied refrigerant before entering the evaporator thus reducing the loss of refrigerant due to flashing. **Kim et al, [54]**

The COP of a SE chiller ranges from 0.6 to 0.8. The driving temperatures are in the range of 90 to 100°C for a water cooled system and those of air-cooled systems need to be roughly 30 K higher. [ **Kim et al, [54]**]

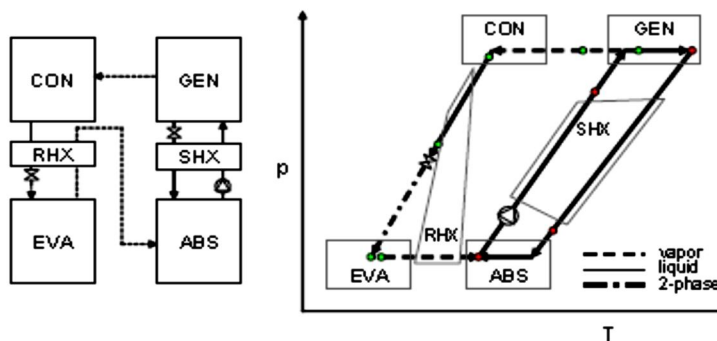

Fig.4 Block and P-T-X Diagram of Single-Effect Absorption Cycle [54]

2) *Double-Effect Cycle:* Fig.5 shows a double-effect absorption cycle. It is basically a SE cycle with an extra generator (high-temperature generator, HT-GEN in Fig.5) and another heat exchanger (HT-SHX) between the two generators. The extra generator is designed to operate at such a high pressure that its refrigerant vapor condenses at a temperature which is high enough to boil the solution in the generator of the SE absorption cycle (low-temperature generator, LT-GEN). The result is an increased COP. The particular double-effect cycle in Fig.5 is a serial flow type, which means that the whole solution from the absorber goes through the two generators in series. In a parallel-flow double-effect cycle, after the LT-HEX one part of the solution

## International Journal for Research in Applied Science & Engineering Technology (IJRASET)

flows to the HT-GEN and the other flows to the LT-GEN. Since the HT-GEN operates at a high pressure, this cycle is not practical for a refrigerant with a low boiling temperature like ammonia.

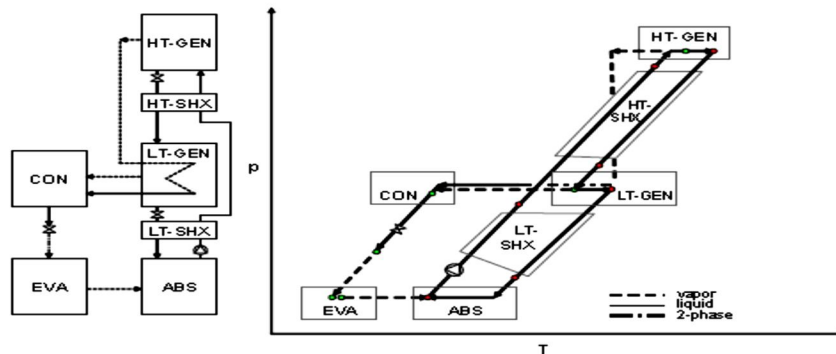

Fig.5 Block And P-T-X Diagram Of Double-Effect Absorption Cycle [54]

The highest pressure in a double-effect LiBr-water cycle approaches atmospheric pressure. The COP of a typical water-cooled double-effect LiBr-water chiller ranges between 1.2-1.3 and the driving temperature is in the range of 150-170°C. **Kim et al, [54]**

3) *Half-Effect Cycle*: Although no half-effect absorption chiller is listed in Table 1, this cycle is included here because it is promising for application to solar absorption cooling as suggested by **Kim and Machielsen [57]**

Fig. 6 shows one of the low-temperature cycles known by such names as “two-stage” or “half-effect” absorption cycles.

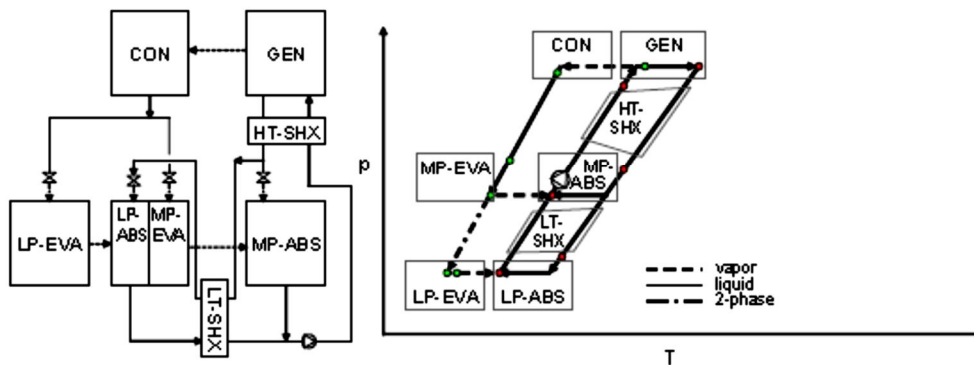

Fig.6 Block and P-T-X Diagram Of Heat-Coupled Parallel-Flow Half-Effect Cycle [54]

Among the different names, “half-effect” is preferred because “two-stage” is a very general term that would even encompass a double-effect cycle. The name, half-effect has been given in line with the ideas of “single-” and “double-effect” cycles because this cycle has roughly half of a single-effect cycle’s COP. Among various half-effect cycles, the cycle in Fig.6 can best be characterized by the heat-coupled absorber (LP-ABS)-evaporator (MP-EVA) configuration. This is the reason why it has been named “heat-coupled”. **Kim et al, [54]**

The cycle has a single generator (GEN in Fig.6) and condenser (CON) but two evaporators (LP- and MP-EVA), two absorbers (LP- and MP-ABS) and two solution heat exchangers (LT- and HT-SHX). The functions of the generator and condenser are the same as in other cycles. The liquefied refrigerant from the condenser is split into two flows and distributed to LP-EVA (low-pressure evaporator) and MP-EVA (mid-pressure evaporator). Among the two absorbers, LP-ABS (low-pressure absorber) is in thermal contact, i.e. “heat-coupled”, with MP-EVA as shown in the block diagram, which means that the evaporating refrigerant in MP-EVA cools down the LP-ABS. In this configuration, refrigeration effect is attained only in LP-EVA and the removed heat from the cold heat source is transferred firstly by mass transfer (i.e. absorption of vapor) from LP-EVA to LP-ABS, by heat conduction from LP-ABS to MP-EVA, then again by mass transfer from MP-EVA to MP-ABS where it is finally rejected to the environment. The biggest advantage with this cycle in solar cooling application is that the generator temperature is significantly



## International Journal for Research in Applied Science & Engineering Technology (IJRASET)

lower than for the other cycles. Disadvantages are, firstly, complicated system configuration and secondly, a reduced COP. The name “parallel-flow” has been used to differentiate the cycle presented in Fig. 6 from another half-effect cycle. As shown in Fig. 6, all solution first flows to the generator and it is then split to proceed to the two absorbers in parallel. However this solution flow can also be configured to flow through the two absorbers in series as shown in Fig. 7a. Another example of half-effect cycle is shown in Fig. 7b. This cycle is a combination of two single-effect cycles where the absorber of one cycle is “mass-coupled” to the generator of the other. **Kim et al, [54]**

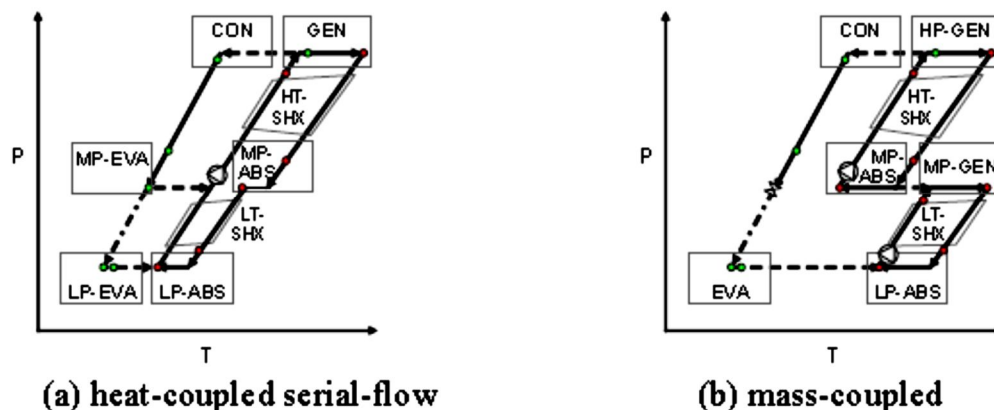

Fig.7 Other Half-Effect Cycles [54]

The COP of a half-effect cycle ranges between 0.3 and 0.4. Typical driving temperatures for water-cooled half-effect cycles are in the range of 60 to 70°C. Air-cooled cycles would require driving temperatures about 30 K higher than this temperature level. **Kim et al, [54]**

4) *Gax Cycle*: This cycle has been named after one of its components, which is the generator-absorber heat exchanger (GAX in Fig.8). **Kim et al, [54]**

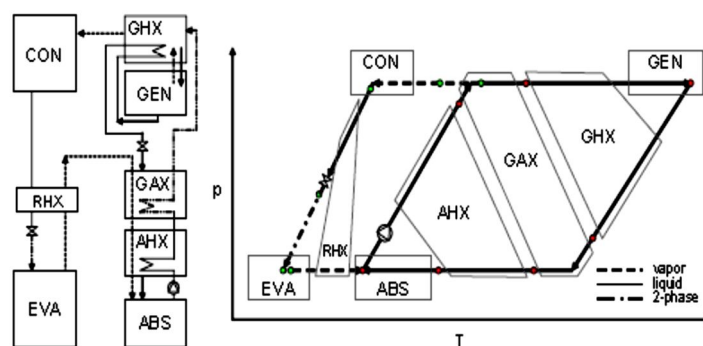

Fig.8 Block And P-T-X Diagram Of Double-Effect Absorption Cycle [54]

As shown in Fig.8, this cycle operates in a wide temperature range. After the generation process is finished in the generator (GEN in Fig.8), the solution temperature has reached a very high level. This high-temperature solution is reused to boil off extra refrigerant from the colder solution first in the generator heat exchanger (GHX) and then in the GAX. Difference between GHX and GAX is that GAX has two-phase flows on both sides, i.e. generation in the cold side and absorption in the hot side. Thanks to this heat recovery, extra refrigerant is generated resulting in a higher COP. There is another heat exchanger called absorber heat exchanger (AHX) between GAX and an ordinary absorber at the bottom, which is cooled by the coldest solution in the cycle. When there is no GAX or GAX is not working properly due to low driving temperatures, the GAX cycle becomes an AHX cycle working at a lower temperature level and its COP decreases. Because GAX cycles require a working fluid that is stable in a wide temperature range, aqueous ammonia solution is typically used. In a  $\text{NH}_3\text{-H}_2\text{O}$  GAX cycle, the role of the rectifier is very important because the refrigerant

## International Journal for Research in Applied Science & Engineering Technology (IJRASET)

erant vapor leaving the high-temperature generator has a low purity. **Kim et al, [54]**

Another interesting characteristic of the GAX cycle is that its COP increases continuously as the driving temperature increases, which is quite different from the other absorption cycles where the COP is more or less constant over the entire operating temperature range. For example, Fig.9 shows a COP vs. generator temperature curve quoted from **Kim and Machielsen [58]**. Since the GAX cycle in Fig.9 operates as an AHX cycle in the lower temperature range, its COP continuously follows the COP of the AHX and the GAX cycles in the corresponding temperature range.

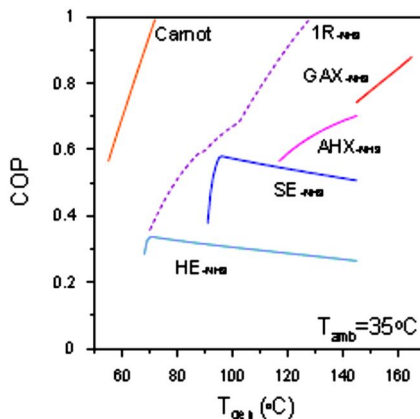

Fig.9 COP of Various NH<sub>3</sub>-H<sub>2</sub>O Cycles **Kim And Machielsen, [57]**

### III. VAPOR ABSORPTION SYSTEM

Vapor Absorption system is an attractive method for utilizing low grade energy directly for cooling while the vapor absorption system utilizes high grade energy. The other important feature of vapor absorption system is that it uses no moving component except solution pump. Vapor absorption system consists of four basic components viz. an evaporator, an absorber (located on low pressure side), a generator and a condenser (located on high pressure side). A refrigerant flows from the condenser to the evaporator, then via absorber to the generator and back to condenser, while the absorbent passes from absorber to the generator and back to absorber. For maximum efficiency, the pressure difference between the low pressure side and high pressure side is maintained as small as possible. Although, the initial cost of these systems is at present higher but their operating expenses are often appreciably lower, which can further be reduced if efficient absorption and distillation can be achieved. Since, the efficiency of these processes is determined largely by thermodynamic properties of the refrigerant –absorbent combination, an extensive study of these properties is of utmost importance in the development of an efficient absorption refrigeration cycle.

Many researchers have carried out studies of vapor absorption refrigeration using different working fluid pairs and the most common working pairs are LiBr-H<sub>2</sub>O and NH<sub>3</sub>-H<sub>2</sub>O.

Alizadeh et al [59] achieved theoretical study on design and optimization of water – lithium bromide refrigeration cycle. They concluded that for a given refrigerating capacity higher generator temperature causes high cooling ratio with smaller heat exchange surface and low cost. The crystallization effect is a limiting factor for water lithium bromide cycles.

Anand and Kumar [60] carried out availability analysis and calculation of irreversibility in system components of single and double effect series flow of LiBr-water absorption system. The assumed parameters for computation of results were the condenser and absorber temperatures which were equal to 87.8°C and 140.6°C for single effect and double effect systems respectively.

Tyagi [61] carried out the detailed study on aqua-ammonia VAR system and plotted the coefficient of performance, mass flow rates as functions of operating parameters i.e. absorber, evaporator and generator temperatures. He showed that COP and work done are functions of evaporator, absorber, condenser and generator temperatures and also depends on the properties of binary solution.

Ercan and Gogus [62] analyzed the irreversibility's in components of aqua-ammonia absorption refrigeration system by second law analysis. They calculated the dimensionless exergy loss of each component, exergetic coefficient of performance, coefficient of performance and circulation ratio for different generator, absorber evaporator and condenser temperatures. They concluded that aqua-ammonia system needs a rectifier for high ammonia concentrations but it will lead to additional exergy loss in the system. They observed the highest exergy loss in evaporator followed by absorber. It was also concluded that the dimensional less total exergy loss depends on generator temperature.

## International Journal for Research in Applied Science & Engineering Technology (IJRASET)

Oh et al [63] investigated a gas fired, air cooled LiBr/H<sub>2</sub>O double effect parallel flow type absorption heat pump of 2TR being used as an air conditioner. They investigated the performance of the absorption heat pump in the cooling mode through cycle simulation. They obtained the system characteristics depending on the inlet temperature of air to the absorber, the working solution concentration, the solution distribution ratio of the mass of the solution into the first generator to the total mass of the solution from the absorber, and the leaving temperature differences of the heat exchanging components. They concluded that there exists a critical value of the solution distribution ratio that maximizes the cooling performance of the system.

Aphornratana and Eames [64] investigated single effect water lithium bromide system using exergy analysis approach. It was shown that the irreversibility in generator was highest followed by absorber and evaporator.

Bell et al [65] developed a LiBr-H<sub>2</sub>O experimental absorption cooling system driven by heat generated by solar energy. The components of the system are housed in evacuated glass cylinders to observe all the processes. They determined the thermodynamic performance of the system by applying mass and energy balance for all the components. Their work was based on the assumption that the working fluids are in equilibrium and the temperature of the working fluid leaving the generator and absorber is equal to the temperature of generator and absorber respectively. They concluded that the COP of the system depends on generator temperature and there is optimum value of generator temperature at which COP is maximum. They also concluded that by operating the system at low condenser and absorber temperatures a satisfactory COP is obtained at a generator temperature as low as 68°C.

Horuz [66] explained the fundamental vapor absorption refrigeration system and carried out a comparative study of such system based on ammonia-water and Lithium Bromide-water working pairs. The comparison of the two systems was presented in respect of COP, cooling capacity and maximum and minimum pressures. He concluded that VAR system based on Lithium Bromide-water is better than ammonia-water. However, problem of crystallization lies with Lithium Bromide-water system.

Talbi and Agnew [67] carried out exergy analysis on single effect absorption refrigeration cycle with Lithium Bromide-water as the working fluid pair. They developed a computer simulation model based on heat and mass balance, heat transfer equations and thermodynamic properties. The cycle collects free energy from the exhaust of diesel engine. They calculated the dimensionless total exergy loss and exergy loss of each component. They found that the absorber has the highest exergy loss of 59.06% followed by generator. They concluded that the absorption refrigeration cycle is effective in demonstrating the advantages of exergy process which are otherwise not accounted in the heat balance method.

Lee and sheriff [68] carried out the second law analysis of a single effect Lithium Bromide-water absorption refrigeration system. The effect of heat source temperature on COP and exergetic efficiency was evaluated. However, they did not analyze effect of variation in absorber and condenser temperatures and also the effectiveness of solution heat exchanger was also not specified.

Lee and sheriff [69] carried out the second law analysis of single effect and various double effect Lithium Bromide-water absorption chillers for chilled water temperature of 7.22°C and cooling water temperatures 29.4°C and 35°C and computed COP and exergetic efficiency. The effect of heat source temperature on COP and exergetic efficiency was investigated. In this study, the effectiveness values of solution heat exchangers considered for analysis has not been specified and their results were only valid for water cooled systems.

Sozen [70] studied the effect of heat exchangers on the system performance in an ammonia-water absorption refrigeration system. Thermodynamic performance of the system was analyzed and the irreversibility's in the system components have been determined for three different cases. The COP, ECOP, circulation ratio, and non-dimensional exergy loss of each component of the system was calculated. They concluded that the evaporator, absorber, generator, mixture heat exchanger and condenser showed high non-dimensional exergy losses. They also concluded that using refrigerant heat exchanger in addition to mixture heat exchanger does not improve the system performance.

Fernandez-Seara and Vazquez [71] studied the optimal generator temperature in single stage ammonia-water absorption refrigeration system. They studied the behavior of this temperature on thermal operating conditions and system design parameters. They carried out a parametric analysis by developing a computer program and based on the results they designed a control system. The control system developed maintains a constant temperature for the space to be refrigerated and also control the optimal temperature in the system generator.

De Francisco et al [72] developed and tested the prototype of a 2 kW capacity ammonia-water absorption system operating on solar energy for rural applications. The system suffered from leakages in different components and need further improvements. They concluded that the efficiency of the system is very low and improved prototype has to be developed.

Horuz and Callander [73] described the experimental investigation of the performance of a commercially available absorption refrigeration system. The system is natural gas fired with a capacity of 10 kW. They studied the response of the refrigeration system to

## International Journal for Research in Applied Science & Engineering Technology (IJRASET)

variations in chilled water temperature, chilled water level in evaporator drum; chilled water level flow rate and variable heat input. They concluded that the lower the energy input, the lower will be the cooling effect.

De Lucas et al [74] studied the use of alternative absorbent in absorption refrigeration cycles to replace the existing absorbent. New absorbent used is a mixture of lithium bromide and potassium formate in a 2:1 w/w. The performance of the system was compared by developing a program. They concluded that less energy is required in the generator and due to this; waste heat with a temperature of 328.15 K is required. The efficiency of the system was increased and the new absorbent is less corrosive and less expensive to manufacture.

Sencan et al [75] carried out the exergy analysis of a single effect Lithium Bromide-water absorption refrigeration system and calculated the exergy losses in the system components. The effect of heat source temperature on COP and exergetic efficiency was computed. They did not analyze the effect of variation in absorber and condenser temperature. They concluded that the cooling and heating COP of the system increases slightly when increasing the heat source temperature but the exergetic efficiency of the system decreases for both cooling and heating applications.

Kilic and Kaynakli [76] investigated a single effect and a series flow double effect vapor absorption systems using energy analysis approach. The effect of different parameters on COP such as generator temperature, absorber temperature, condenser temperature, solution circulation ratio and solution concentration, etc... had been investigated. Their results revealed that COP of double effect absorption refrigeration system was higher than that of the single effect system.

Kilic and Kaynakli [77] used the first and second laws of thermodynamics to analyze the performance of a single stage Lithium Bromide-water absorption refrigeration system by varying some working parameters. They introduced a mathematical model based on exergy method. They found that the performance of the ARS increases with increasing generator and evaporator temperatures but decreases with increasing condenser and absorber temperatures. They concluded that the highest exergy loss occurs in generator regardless of operating conditions and therefore it is the most important component of the system.

Gong et al [78] presented the method of product exergy cost for scheme selection optimization of cooling and heating source system of air conditioning system. They developed the optimization algorithm which adopts an integrative; multiple objective decision method with the analysis of the product exergy cost and concluded that the method is scientific and reliable.

Kaynakli and Yamankaradeniz [79] performed calculations for a 10 kW cooling load system. The evaporator and condenser temperatures were taken as 4°C and 38°C respectively. The generator temperature was taken as 90°C. Effectiveness of solution heat exchanger was assumed as 0.5 and efficiency of pump was assumed equal to 0.9. They concluded that entropy generation of the generator is an important fraction of the total entropy generation in the system basically due to the temperature difference between the heat source and the working fluid and in order to decrease the total entropy generation of the system, the generator should be developed further.

Morosuk and Tsatsaronis [80] used an absorption refrigeration machine to represent splitting the exergy destruction into endogenous/exogenous and unavoidable/avoidable parts which is a new development in the exergy analysis of energy conversion systems. They concluded that advanced exergetic evaluation of an ARM supplies useful additional information which is not provided by exergy analysis. The avoidable exergy destruction identifies the potential for improving each system component.

Gomri and Hakimi [81] carried out exergy analysis of double effect Lithium Bromide-water absorption refrigeration system. They showed that the performance of the system increases with increasing LP generator temperature, but decreases with increasing HP generator temperature. They concluded that the highest exergy loss occurs in the absorber and in the HP generator and therefore the absorber and HP generator are the most important components of the double effect refrigeration system.

Gomri [82] carried out a comparative study between single effect and double effect absorption refrigeration systems. They developed a computer program based on energy balances and thermodynamic properties to carry out thermodynamic analysis. They concluded that for each condenser and evaporator temperature, there is an optimum generator temperature where change in exergy of single effect and double effect absorption refrigeration system is minimum. Their study showed that the COP of double effect system is approximately twice the COP of single effect system but there is marginal difference between the exergetic efficiencies of both systems.

Kaushik and Arora [83] presented the energy and exergy analysis of a single effect and a series flow double effect Lithium Bromide-water absorption system. They developed a computational model for the parametric investigation. Their analysis involved the effect of generator, absorber and evaporator temperatures on the energetic and exergetic performance. They concluded that the irreversibility is highest in the absorber in both systems as compared to other systems.

Zhu and Gu [84] used the first and second laws of thermodynamic to analyze the performance of ammonia–sodium thiocyanate ab-

## International Journal for Research in Applied Science & Engineering Technology (IJRASET)

sorption system for cooling and heating applications. A mathematical model based on exergy analysis was developed. The performance of the system was analyzed using different operating conditions. They concluded that the cooling and heating COPs increase with increasing generator and evaporator temperatures but decrease with increasing condenser and absorber temperatures.

Garousi Farshi et al [85] developed a computational model to study and compare the effects of operating parameters on crystallization phenomena in three classes of double effect Lithium Bromide–water absorption refrigeration systems (series, parallel and reverse parallel) with identical refrigeration capacities. They concluded that the range of operating conditions without crystallization risks in the parallel and the reverse parallel configurations was wider than those of the series flow system.

Behrooz and Ziapour [86] carried out a thermodynamic analysis of a diffusion absorption refrigeration heat pipe (DARHP) cycle. A computer code was modified for an ammonia–water DARHP cycle with helium as the auxiliary inert gas using EES software. The second law efficiency was examined parametrically by the computer simulation. They validated the model by comparison with previously published experimental data for DARHP system. The cycle performance results under different conditions indicated that the best performance was obtained for the concentration rich solution of 0.35 ammonia mass fraction and the concentration of weak solution about 0.1. They concluded that the exergy losses in the evaporator, condenser and dephlegmator were small. They also found that the second law efficiency increased with increasing evaporator temperature; and decreased with increasing thermo siphon temperature.

Khaliq et al [87] carried out an investigation of waste heat based combined power and ejector-absorption refrigeration cycle based on first and second laws of thermodynamic analysis. The working fluid was R141b. Estimates for irreversibility of individual components of the cycle lead to possible measures for performance improvement. Results showed that around 53.6% of the total input exergy is destroyed due to irreversibility in the components, 22.7% is available as a useful exergy output, and 23.7% is exhaust exergy lost to the environment, whereas energy distribution showed that 44% is exhaust energy and 19.7% is useful energy output. They concluded that proposed cogeneration cycle yields much better thermal and exergy efficiencies than the previously investigated cycles and the current investigation clearly showed that the second law analysis is quantitatively visualizes losses within a cycle and gives clear trends for optimization.

### BIBLIOGRAPHY

- [1] Niebergall, W., 1981, Sorptions -Kaltmaschinen, Handbuch der Kältetechnik; Bd. 7, Springer -Verlag, Berlin
- [2] Thévenot, R., 1979, A history of refrigeration throughout the world, Int. Inst. Refrigeration Paris.
- [3] Stephan, K., 1983, History of absorption heat pumps and working pairs developments in Europe, Int. J. Refrigeration, Vol. 6, pp. 160-166
- [4] Yazaki Energy Systems Inc., 2005, Specifications of water-fired chillers and chiller-heaters at <http://www.yazakienergy.com/waterfiredspecifications.htm>, the last access on 06 Dec. 2006
- [5] Löf, G.O.G., Tybout, R.A., 1974, The design and cost of optimized systems for residential heating and cooling by solar energy, Solar Energy, Vol. 16, pp. 9-18
- [6] Ward, D.S. and Löf, G.O.G., 1975, Design and construction of a residential solar heating and cooling system, Solar Energy, Vol. 17, pp. 13-20
- [7] Ward, D.S., Duff, W.S., Ward, J.C., Löf, G.O.G., 1979, "Integration of evacuated tubular solar collectors with lithium bromide absorption cooling systems, Solar Energy", Vol. 22, pp. 335-34
- [8] Hattem, D.V., Dato, P.A., 1981, Description of an active solar cooling system, using a LiBr- H<sub>2</sub>O absorption machine, Energy and Buildings, Vol. 3, pp. 169-1
- [9] Al-Karaghoul, A., Abood, I., Al-Hamdani, N.I., 1991, The solar energy research center building thermal performance evaluation during the summer season, Energy Conversion and Management, Vol. 32, pp. 409-417
- [10] Best, R., Ortega, N., 1999, Solar refrigeration and cooling, Renewable Energy, Vol. 16, pp.685-690
- [11] Izquierdo, M., Syed, A., Rodriguez, P., Maidment, G., Missenden, J., Lecuona, A., Tozer, R., 2005, A novel experimental investigation of a solar cooling system in Madrid, Int. J. Refrigeration, Vol. 28, pp. 859-871
- [12] Storkenmaier, F., Harm, M., Schweigler, C., Ziegler, F., Albers, J., Kohlenbach, P., Sengewald, T., 2003 Small-capacity water/LiBr absorption chiller for solar cooling and waste-heat driven cooling, Proc. of International Congress of Refrigeration, Washington D.C., USA
- [13] Safarik, M., Richter, L., Mockel, F., Kretschmar, S., 2005, Performance data of a small capacity absorption chiller, Proc. of International Conference Solar Air-conditioning, Bad Staffelstein, Germany
- [14] Ishibashi, T., 1979, the operation results of the Yazaki experimental solar house, Silver Jubilee Congress of ISES, Atlanta, USA
- [15] Lamp, P. and Ziegler, F., 1998, European research on solar-assisted air conditioning, Int. J. Refrigeration, Vol. 21, pp.89-99
- [16] Lokurlu, A., Müller, G., 2005, Experiences with the worldwide first solar cooling system based on trough collectors combined with double effect absorption chillers, Proc. Of International Conference Solar Air-conditioning, Bad Staffelstein, Germany
- [17] Trombe, F., Foex, M., 1957, the production of cold by means of solar radiation, Solar Energy, Vol. 1, pp. 51-52
- [18] Chinnappa, J., 1961, experimental study of the intermittent absorption refrigeration cycle employing the refrigerant-absorbent systems of ammonia-water and ammonia-lithium nitrate, Solar Energy, Vol. 5, pp. 1-18
- [19] Paassen, J.P. van, 1987, Solar powered refrigeration by means of an ammonia-water intermittent absorption cycle, Delft University of Technology, Laboratory of Refrigeration and Indoor Climate Technology, Report no. K127, ISBN 90-370-0013-4
- [20] Gutiérrez, F., 1988, Behavior of a household absorption-diffusion refrigerator adapted to autonomous solar operation, Solar Energy, Vol. 40, pp. 17-2
- [21] Kunze, G., 2000, Efficient solar cooling with an improved ammonia-absorption system, Renewable Energy World, Vol. 3, pp. 111-112

## International Journal for Research in Applied Science & Engineering Technology (IJRASET)

- [22] Jakob, U., Eicker, U., Taki, A.H., Cook, M.J., 2003, Development of an optimized solar driven diffusion-absorption cooling machine, Proc. of ISES Solar World Congress 2003, Göteborg, Sweden
- [23] Shiran, Y., Shitzer, A., Degani, D., 1982, Computerized design and economic evaluation of an aqua-ammonia solar operated absorption system, Solar Energy, vol. 29, pp. 43-54
- [24] McLinden, M.O., Klein, S.A., 1983, Simulation of an absorption heat pump, solar heating and cooling systems, Solar Energy, Vol. 31, pp. 473-482
- [25] Alvares, S.G., Trepp, Ch., 1987, Simulation of a solar driven aqua-ammonia absorption refrigeration system Part2: viability for milk cooling at remote Brazilian dairy farms, Int. J. Refrigeration, Vol. 10, pp. 70-76
- [26] Best, R., Ortega, N., 1999, Solar refrigeration and cooling, Renewable Energy, Vol. 16, pp. 685-690
- [27] ARTISC, 2003, Refrigeration, heating and air-conditioning using an absorption refrigeration system heated by transparently insulated solar collectors, EU project, Fifth Framework Program. CRAFT/70436/1999
- [28] SACE, 2003, Solar Air conditioning in Europe: Final Report, EC project NNE5/2001/25
- [29] Richter, L., Safarik, M., 2005, Solar cooling with Ammonia water absorption chillers, Proc. Of International Conference Solar Air conditioning, Bad Staffelstein, Germany
- [30] Chinnappa, J.C.V., Martin, H.V., 1976, Dual-mode operation by solar energy of an ammonia-water two-stage cycle: A comparative study, Solar Energy, Vol. 18, pp. 337-342
- [31] Sofrata, H., Khoshaim, B., Nasser, A., Megahed, M., 1981, A solar-powered LiBr dual cycle, Applied Energy, Vol. 9, pp. 185-191
- [32] Alizadeh, S., 2000, Multi-pressure absorption cycles in solar refrigeration: a technical and economical study, Solar Energy, Vol. 69, pp.37-44
- [33] Gökün, S., Er, I.D., 2001, the optimum performance of a solar-assisted combined absorption-vapor compression system for air conditioning and space heating, Solar Energy, Vol. 71, pp. 213-216
- [34] Sawada, N., Tanaka, T., Mashimoto, K., 1994, Development of organic working fluid and application to absorption systems, Proc. of Absorption Heat Pump conference, AES-Vol.31,ASME, New Orleans, US
- [35] Romero, R.J., Rivera, W., Pilatowsky, I., Best, R., 2001, Comparison of the modeling of a solar absorption system for simultaneous cooling and heating operating with an aqueous ternary hydroxide and with water/lithium bromide, Solar Energy Materials and Solar Cells, Vol. 70, pp. 301-308
- [36] Arivazhagan, S., Murugesan, S.N., Saravanan, R., Renganarayanan, S., 2005, Simulation studies on R134a-DMAC based half effect absorption cold storage systems, Energy Conversion and Management, Vol. 46, pp. 1703-1713
- [37] Zhuo, C., 1995, Absorption heat transformer with TFE-Pyr as the working pair, Dissertation, TU Delf
- [38] Stuart, L., Sheridan, G.N.R., 1977, Modeling of a solar-operated absorption air conditioner system with refrigerant storage, Solar Energy, Vol. 19, pp. 691-70
- [39] Anand, D.K., Allen, R.W., Kumar, B., 1982, Transient simulation of absorption machines, J.of Solar Energy, Vol. 104, pp 197-20
- [40] Kaushik, S.C., Sheridan, N., Lam, K., Kaul, S., 1985, Dynamic simulation of an ammonia-water absorption cycle solar heat pump with integral refrigerant storage, J. of Heat Recovery Systems, Vol. 5., pp. 101-11
- [41] Alvares, S.G., Trepp, Ch., 1987, Simulation of a solar driven aqua-ammonia absorption refrigeration system Part2: viability for milk cooling at remote Brazilian dairy farms, Int. J. Refrigeration, Vol. 10, pp. 70-76
- [42] Butz, D., Stephan, K., 1989, Dynamic behavior of an absorption heat pump, Int. J. of Refrigeration, Vol. 2, pp. 201-21
- [43] Sano, J., Hihara, E., Saito, T., Nagaoka, Y., Nishiyama, N., 1991, Dynamic simulation of an absorption refrigerating machine, Proc. of Absorption Heat Pump Conference, Tokyo, Japan, pp. 133-13
- [44] Jeong, S., 1990, Simulation des dynamischen Verhaltens einer periodisch wirkenden Absorptionswärmepumpe mit dem Stoffgemisch Ammoniak/Wasser, Dissertation, Technical University Aachen
- [45] Kaushik, S.C., Rao, S.K., Kumari, R., 1991, Dynamic simulation of an aqua-ammonia absorption cooling system with refrigerant storage, Energy Convers. Mgmt., Vol. 32, pp 197-206
- [46] Jeong, S., Kang, B.H., Karng, S.W., 1998, Dynamic simulation of an absorption heat pump for recovering low grade waste heat, Applied Thermal Engineering, Vol. 18, pp. 1-12
- [47] Bina, J., Radermacher, R., Moran, D., 2005, Transient simulation of an absorption chiller in a CHP system, Proc. of Int. Sorption Heat Pump Conference, Denver, USA
- [48] Kohlenbach, P., Ziegler, F., 2006, Development of a dynamic simulation model for transient absorption chiller performance, Proc. of 7<sup>th</sup> IIR Gustav Lorentzen Conf. on Natural Working Fluids, Trondheim, Norwa
- [49] Fu, D.G., Poncia, G., Lu, Z., 2006, Implementation of an object-oriented dynamic modeling library for absorption refrigeration systems, Applied Thermal Engineering, Vol. 26, pp. 217- 225
- [50] Butz, D., Stephan, K., 1989, Dynamic behavior of an absorption heat pump, Int. J. of Refrigeration, Vol. 12, pp. 201-212
- [51] Collector Catalogue 2004, 2004, Institut für Solartechnik SPF, Rapperswil, Switzerland
- [52] Garimella, S., Lacy, D., Stout, R.E., 1997, Space-conditioning using triple-effect absorption heat pumps, Applied Thermal Engineering, pp. 1183-119
- [53] Stitou, D., Spinner, B., Satzger, P., Ziegler, F., 2000, Development and comparison of advanced cascading cycles coupling a solid/gas thermochemical process and a liquid/gas absorption process, Applied Thermal Engineering, Vol. 20, pp. 1237-126
- [54] im, D.S., Machielsen, C.H.M., 2002, Evaluation of air-cooled solar absorption cooling systems, Proc. of ISHPC 2002, Shanghai, China
- [55] Worek, W.M., Ludovisi, D., Meckler, M., 2003, Enhancement of a double-effect absorption cooling system using a vapour recompression absorber, Energy, Vol. 28pp. 1151-1163
- [56] Schweigler, C., Hiebler, S., Kren, C., Mehling, H., 2005, Low temperature heat storage for solar heating and cooling applications, Proc. of International Conference Solar Air Conditioning, Bad Staffelstein, Germany
- [57] Kim, D.S., Machielsen, C.H.M., 2002b, Comparative study on water- and air-cooled solar absorption chillers, Proc. of EuroSun 2002 ISES Conference, Bologna, Italy
- [58] D.S, Machielsen, C.H.M., 2002a, Comparative study on water- and air-cooled solar absorption chillers, Proc. of EuroSun 2002 ISES Conference, Bologna, Italy
- [59] Alizadeh, S., Bahar, F., Geoola, F., Design and optimization of an absorption refrigeration system operated by solar energy, Solar Energy, Vol. 22, (1997),pp.

## International Journal for Research in Applied Science & Engineering Technology (IJRASET)

149-154

- [60] Anand, D.K., Kumar, B., Absorption machine irreversibility using new entropy calculations, *Solar Energy*, Vol.39, (1987), pp. 243-256
- [61] Tyagi, K.P., Design parameters of an aqua-ammonia vapor absorption refrigeration system, *Heat recovery systems & CHP*, Vol. 8(4), (1988), pp. 375-377
- [62] Ercan Ataer, O. Gogus, Yalcin., Comparative study of irreversibilities in an aqua-ammonia absorption refrigeration system, *International Journal of Refrigeration*, Vol.14, (1991), pp. 86-92
- [63] Oh, M.D., Kim, S.C., Kim, Y.I., and Kim, Y.I., Cycle analysis of an air cooled LiBr/H<sub>2</sub>O absorption heat pump of parallel flow type, *International Journal of Refrigeration*, Vol. 17, (1994), pp. 555-565
- [64] Aphornratana, S., Eames, I.W., Thermodynamic analysis of absorption refrigeration cycles using second law of thermodynamics method, *International Journal of Refrigeration*, Vol. 18(4), (1995), pp. 244-25
- [65] Bell, I.A., Al-Daini, A.J., Al-Ali, Habib., Abdel-Gayed, R.G., and Duckers, I., The design of an evaporator/absorber and thermodynamic analysis of a vapor absorption chiller driven by solar energy, *World Renewable Energy Congress*, (1996), pp. 657-66
- [66] Horuz, I., A comparison between ammonia-water and LiBr-water solutions in vapor absorption refrigeration systems, *Heat and Mass Transfer*, Vol. 25(5), (1998), pp. 711-721
- [67] , M.M., and Agnew, B., Exergy analysis: an absorption refrigerator using lithium bromide and water as the working fluids, *Applied Thermal Engineering*, Vol.20, (2000), pp. 619-630
- [68] Lee, S.F., Sherif, S.A., Thermodynamic analysis of a lithium bromide/water absorption system for cooling and heating applications, *International Journal of Energy Research*, Vol.25, (2000), pp.1019-103
- [69] Lee, S.F., Sherif, S.A., Second law analysis of various double effect lithium bromide/water absorption chillers. *ASHRAE Transactions*, Vol. 09 (5), (2000), pp. 664-673
- [70] Sozen, A., Effect of heat exchangers on performance of absorption refrigeration systems, *Energy Conversion and Management*, Vol. 42, (2001), pp. 1699-1716
- [71] Fernandez-Seara, Jose and Vazquez, M., Study and control of the optimal generation temperature in NH<sub>3</sub>-H<sub>2</sub>O absorption refrigeration systems, *Applied Thermal Engineering*, Vol. 21, (2001), pp. 343-357
- [72] De Francisco, A., Illanes, R., Torres, J.L., Castillo, M., De Blas, M., Prieto, E., Garcia, A., Development and testing of a prototype of low-power water-ammonia absorption equipment for solar energy applications, *Renewable Energy*, Vol. 25, (2002), pp. 537-544
- [73] oruz, I. and Callander, T.M.S, Experimental investigation of a vapor absorption refrigeration system, *International Journal of Refrigeration*, Vol. 27,(2004), pp. 10-16
- [74] De Lucas, Antonio., Donate, Marina., Molero, Carolina., Villasenor, Jose.,Rodriguez, Juan F., Performance evaluation and simulation of a new absorbent for an absorption refrigeration system, *International Journal of Refrigeration*, Vol. 27, (2004), pp. 324-330
- [75] Sencan, A., Yakut, K.A., Kalogirou, S.A., Exergy analysis of lithium bromide /water absorption systems, *Renewable Energy*, Vol. 30, (2005), pp.645-657
- [76] Kilic, M. and Kaynakli, O., Second law-based thermodynamic analysis of waterlithium bromide absorption refrigeration system, *Energy*, Vol.32, (2007), pp.1505-1512
- [77] Kilic, M. and Kaynakli, O., Theoretical study on the effect of operating conditions on performance of absorption refrigeration system, *Energy Conversion and Management*, Vol. 48, (2007), pp. 599-607
- [78] Gong, G., Zeng, W., Chang, S., He, J., Li, K., Scheme-selection optimization of cooling and heating sources based on exergy analysis, *Applied Thermal Engineering*, Vol. 27, (2007), pp. 942-95
- [79] Kaynakli, O., Yamankaradeniz, R., Thermodynamic analysis of absorption refrigeration system based on entropy generation, *Current Science*, Vol.92(4), (2007), pp. 472-479
- [80] Morosuk, T., Tsatsaronis, G., A new approach to the exergy analysis of absorption refrigeration machines, *Energy*, Vol. 33, (2008), pp. 890-907
- [81] Gomri, R., Hakimi, R., Second law analysis of double effect vapor absorption cooler system, *Energy Conversion and Management*, Vol. 49(11), (2008), pp.3343-3348
- [82] omri, R., Second law comparison of single effect and double effect vapour absorption refrigeration systems, *Energy Conversion and Management*, Vol. 50,(2009), pp. 1279-1287
- [83] Kaushik, S.C., Arora, A., Energy and Exergy analysis of single effect and series flow double effect water-lithium bromide absorption refrigeration systems, *International Journal of Refrigeration*, Vol. 32, (2009), pp. 1247-1258
- [84] , Gu, J., Second law-based thermodynamic analysis of ammonia/sodium thiocyanate absorption system, *Renewable Energy*, Vol.35, (2010), pp. 1940-1946
- [85] Garousi Farshi, L., Mahmoudi, S.M.S., Rosen, M.A., Analysis of crystallization risk in double effect absorption refrigeration systems, *Applied Thermal Engineering*, Vol. 31(10), (2011), pp. 1712-1717
- [86] Behrooz, M., Ziapour, M.T., Performance study on a diffusion absorption refrigeration heat pipe cycle, *International Journal of Thermal Sciences*, Vol.50(4),(2011), pp. 592-598
- [87] Khaliq, A., Agrawal, B.K., Kumar, R., First and second law investigation of waste heat based combined power and ejector-absorption refrigeration cycle, *International Journal of Refrigeration*, Vol. 35(1), (2012), pp. 88-97