



Effects of Natural Radioactivity of Some Chemical and Organic Fertilizers on Gonads in Iraqi Kufa Markets

Abdulhussein A. Alkufi* , Shaymaa A. Kadhim**† , Azhar S. Alaboodi** and Shatha F. Alhous***

*Education Directorate of Najaf, Ministry of Education, Iraq

**Department of Physics, Faculty of Science, University of Kufa, Iraq

***Department of Physics, Faculty of Education for Girls, University of Kufa, Iraq

†Corresponding author: Shaymaa A. Kadhim; shaymaa.alshebly@uokufa.edu.iq

Nat. Env. & Poll. Tech.
Website: www.neptjournal.com

Received: 15-03-2023

Revised: 20-04-2023

Accepted: 24-04-2023

Key Words:

Fertilizers

Cluster analysis

Pearson correlation

AGED

ELCR

ABSTRACT

This study assessed the hazard indicators of common chemical and organic fertilizers widely available in the markets of Najaf Governorate, Iraq. The concentrations of natural radionuclides were measured in thirteen types of fertilizers by Gamma spectrum using NaI(Tl) (3"3) detector. The average radioactivity of the nuclides ^{226}Ra , ^{232}Th , and ^{40}K was (48.91, 37.04, and 702.4675) Bq.kg^{-1} , respectively, for (Di-Aluminum Phosphate) the chemical fertilizers of the type (DAP) and the (nitrogen, phosphorus, and potassium) chemical fertilizers of the type (NPK) the average radioactivity of the nuclides ^{226}Ra , ^{232}Th , and ^{40}K were (35.78, 42.356 and 1519.653) Bq.kg^{-1} , respectively, while the average radioactivity of the organic fertilizers (Orga.) were 55.153, 23.148 and 1451.258 for the three studied nuclei. As for the average values for radium equivalent were 155.967, 213.363, and 200.0023 (Bq.kg^{-1}) for (DAP), (NPK) and organic fertilizers, respectively. The values of the external severity index (H_{ex}), gamma radiation hazard index (I_{γ}), and representative alpha index (I_{α}) were within the permissible limits determined by the UNCEAR 2000. The highest value of total annual effective dose equivalent (TAED) was 1.468 mSv.y^{-1} , the lowest value was 0.302 mSv.y^{-1} , and the mean values were 0.722 mSv.y^{-1} . In contrast, the highest value for annual gonadal dose equivalent (AGED) was $1392.527 \mu\text{Sv.y}^{-1}$, the lowest value was $275.361 \mu\text{Sv.y}^{-1}$, and the average values for all models were $672.135 \mu\text{Sv.y}^{-1}$. The Excess Lifetime Cancer Risk (ELCR), the highest value was 4.039×10^{-3} , the lowest value was 0.833×10^{-3} , and the average value was 1.988×10^{-3} for all fertilizers. The Pearson correlation between radioactive variables and cluster analysis was recognized for the three types of fertilizer samples despite it not being widely accepted. The study can be considered preliminary data for subsequent studies.

INTRODUCTION

Agricultural activities have expanded significantly in recent years. This led to a significant increase in chemical and organ fertilizers (Robinson & Sutherland 2002). Chemical fertilizers are chemical compounds that provide essential nutrients to plants, which have become essential for the agricultural field worldwide. The main raw material used to manufacture fertilizers is phosphate rock with potassium ores and nitrogenous compounds.

The concentration of ^{226}Ra and its decomposition products tend to be higher in phosphate deposits of sedimentary origin (phosphorus is an essential element for plant growth) UNSCEAR200. Therefore, when these rocks are processed into phosphate fertilizers, radionuclides will naturally disperse in the fertilizer and thus become a source of radioactivity in food and the environment (Jibiri & Fasae 2012).

This process leads to potential radiation hazards due to the transfer of radionuclides from agricultural fertilizers to soils and plants, and through the food chain, to humans as this may lead to internal exposure through eating food grown in that agricultural soil.

In addition, some workers can get additional external exposure during the manufacture, packaging, and transportation of fertilizers. Due to the high radioactive content of fertilizers, which may be for employees, producers, and farmers. Accordingly is crucial to determine the normal radioactivity in fertilizers.

These tests also give the foundational information needed to estimate how much radiation is in fertilizers and agricultural land. More than 30 million tons of phosphate fertilizers are used in Iraq each year to boost crop productivity and reclaim land.

The contamination of cultivated land with some naturally occurring radioactive material, however, is a potential drawback of fertilizer. Naturally Occurring Radioactive Materials (NORM) (Lambert et al. 2007). Calculating the radioactivity levels of organic and chemical fertilizers used in the Kingdom of Saudi Arabia, including the ^{226}Ra and ^{232}Th series, their decay products, and ^{40}K . Inorganic fertilizer has a Ra_{eq} of 34.07 to 102.19 Bq.kg^{-1} , while chemical fertilizer ranges from 100.37 to 161.43 Bq.kg^{-1} (El-Taher & Althoyaib 2012).

Due to the importance of the topic from a health point of view, many studies have been conducted about radioactive contamination of fertilizers, where the quantities of ^{226}Ra , ^{232}Th , and ^{40}K in chemical fertilizers led to the calculation of radiation hazard indicators in upper Egypt (Uosif et al. 2014). The average concentrations of ^{226}Ra , ^{232}Th , and ^{40}K in the soil, organic (animal) and inorganic (chemical) as (granular fertilizers), (foliar fertilizers) and (animal fertilizers) were estimated, and the lowest values are observed of specific activities of the same radionuclides were in foliar fertilizer (Faweya et al. 2018).

Another study conducted in Saudi Arabia on fertilizers and obtained results showed significant differences in the radioactive content for ^{226}Ra , ^{232}Th , and ^{40}K in different phosphate fertilizer samples (Khater & Al-Sewaidan 2008).

Based on the foregoing, the current study aims to compare some fertilizers widely spread in Iraq to find out their radioactivity levels. It opens the way for subsequent studies to establish a consistent radioactive database for the concentration of natural radionuclides in some types of local fertilizers used in agricultural soils in Najaf Governorate, Iraq.

COMPONENTS AND TYPES OF FERTILIZERS

The chemical fertilizers available in the local markets are of two types in terms of composition (NPK) and (DAP). Fertilizer (NPK) is a crystalline fertilizer consisting of three main elements: nitrogen (18%) and phosphorus (46%), which is in the form of phosphorous and potassium pent oxide (36%), and these percentages change from one kind to another (Hignett 2018). This fertilizer is characterized by its slow release, granular shape, and easy dissolution, which leads to easy utilization by the plant and enables us to use it by agricultural machinery (Vincevica-Gaile et al. 2019). It is used for all crops and trees in rain-fed or irrigated areas. The second type is the fertilizer (DAP), an abbreviation for the phrase (Di-Aluminum Phosphate), this type consists of phosphorus and nitrogen, but it is free of potassium. These elements are also in different proportions (Knecht & Göransson 2004). A third type is organic fertilizer, prepared from the remains of bones and blood, as well as animal manure (cow, poultry, and goat manure). Plant residues are also included in its ingredients because they contain important mineral elements, such as seaweed, which contains a decent amount of amino acids (Knecht & Göransson 2004). Table 1 represents the studied fertilizers' types, composition, and origin.

SPECIFIC ACTIVITY AND HAZARD INDICES

Specific Activity

Specific activity is the activity per unit mass for radioactive material.

It is measured in units Becquerel per kilogram (Bq.Kg^{-1}) or Curie per gram. The specific activity in Bq.Kg^{-1} units were

Table 1: Types, origins, and components of studied fertilizers.

Sample Code	Fertilizer Components	Origin	Type
F ₁ (Chem-DAP)	(18%) nitrogen and (46%) phosphorous pentoxide, characterized as granular and easy to dissolve, leads to easy use by the plant, enables us to use it by agricultural machines, and is used for all crops and trees, whether in rain-fed or irrigated areas.	Jordan(DAP)	Chemical Fertilizer
F ₂ (Chem-DAP)		Iran(DAP)	Chemical Fertilizer
F ₃ (Chem-DAP)		China(DAP)	Chemical Fertilizer
F ₄ (Chem-DAP)		Egypt(DAP)	Chemical Fertilizer
F ₅ (Chem-NPK)	NPK crystalline fertilizer is slow-release and water-soluble. Phosphorous (P) is derived from mono-ammonium phosphate, and potassium (K) is derived entirely from sulfate. Nitrogen is fixed in ammonia type with (Dicyandiamide DCD), a chemical nitrogen inhibitor. This process allows the ammonia ion (NH ₄) to exist for a longer period in the soil.	Jordan(Npk)	Chemical Fertilizer
F ₆ (Chem-NPK)		Egypt(Npk)	Chemical Fertilizer
F ₇ (Chem-NPK)		Jordan(Npk)	Chemical Fertilizer
F ₈ (Orga.)	The compost was prepared from the remains of bones and blood and animal manure ("cow, poultry, and goat dung). Its components also include plant residues, as they contain important mineral elements. And also seaweed, which contains the right amount of amino acids.	Iraq	Organic Fertilizer
F ₉ (Orga.)		Iraq	Organic Fertilizer
F ₁₀ (Orga.)		Iraq	Organic Fertilizer
F ₁₁ (Orga.)		Iraq	Organic Fertilizer
F ₁₂ (Orga.)		Iran	Organic Fertilizer
F ₁₃ (Orga.)		Canada	Organic Fertilizer

calculated by using equation 1 (Stenström 2011):

$$\mathcal{A}_n = \frac{(C_n - C_b)}{t \varepsilon_\gamma I_g m_s} \quad \dots(1)$$

where \mathcal{A}_n is the specific activity of each radionuclide in Bq.Kg⁻¹, C_n the count rate in cps for a sample, C_b the count rate in cps for background, ε_γ and I_g are detection efficiency and representative level index, t is the counting time and m_s is the mass of the sample in kg.

The Radium Equivalent Activity ($\mathcal{R}a_{eq}$)

The distribution of ²²⁶Ra, ²³²Th, and ⁴⁰K nuclei in soil are not constant.

Radium equivalent activity ($\mathcal{R}a_{eq}$), which is defined as a weighted sum of the activity concentrations of the three radionuclides, including uranium ²²⁶Ra, thorium ²³²Th, and potassium ⁴⁰K,

It was used as a common factor to compare its adverse effects. This factor was calculated using Equation 2.

$$\mathcal{R}a_{eq}(\text{Bq.Kg}^{-1}) = \mathcal{A}_{Ra} + 1.43\mathcal{A}_{Th} + 0.077\mathcal{A}_K \quad \dots(2)$$

Where A_{Ra} is the activity of ²²⁶Ra, A_{Th} is the activity of ²³²Th, and A_K is the activity of ⁴⁰K, all in Becquerel per kilogram (Bq.Kg⁻¹) (Mohanty et al. 2004).

External Hazard Index (H_{ex})

The external risk index is an assessment of the natural gamma radiation risk calculated from equation 3 (Alhous et al. 2020).

$$H_{ex} = \frac{A_{Bi}}{370} + \frac{A_{Th}}{259} + \frac{A_K}{4810} \leq 1 \quad \dots(3)$$

This coefficient must be less than one, and if it is equal to or greater than one, it indicates the presence of a radioactive hazard.

Gamma Radiation Hazard Index (I_γ)

Index (I_γ) estimates the level of γ -radiation hazard associated with the natural radionuclides in specific activity for any matter studied. The derived formula calculates the value (Kadhim 2020).

$$I_\gamma = \frac{A_U}{150} + \frac{A_{Th}}{100} + \frac{A_K}{1500} \quad \dots(4)$$

Another hazard index, the Representative Level Index, I_γ , was determined from the above formula (Alam et al. 1999).

Representative Alpha Index (I_α)

From the equation below, the alpha index was calculated for the samples by using equation 5 (Ziqiang et al. 1988, Adhab et al. 2020):

$$I_\alpha = \frac{A_{Ra}}{200} \quad \dots(5)$$

This hazard index is closely related to radium ²²⁶Ra.

Total Annual Effective Dose Equivalent (TAED)

Exposure risk to any individual due to absorbed dose rate is estimated in terms of the TAED. The Outdoor and Indoor annual effective doses have been obtained, and the total annual effective dose equivalent (mSv.y⁻¹) was calculated using equation 6 (Alam et al. 1999, Aswood 2019).

$$\text{TAED}_{\text{total}}(\text{mSv.y}^{-1}) = D_{\text{eff.out}} + D_{\text{eff.in}} \quad \dots(6)$$

Annual Gonadal Dose Equivalent (AGED):

The impacts of radiation on all living cells vary, which can lead to mutation or cell death. The AGED due to ²²⁶Ra, ²³²Th, and ⁴⁰K was calculated by using the equation 7 (Arafa 2004, Alkufi 2020):

$$\text{AGED}(\mu\text{SV.y}^{-1}) = 3.09A_{Ra} + 4.18A_{Th} + 0.314A_K \quad \dots(7)$$

The gonads are considered organs of interest for dosimetry, according to UNSCEAR (2010). They are the basic reproductive organs. It is also known that an increase in AGED can impact the bone marrow, which makes red blood cells. Leukemia, a blood cancer that frequently results in death, could be resulted. The bladder, lungs, liver, colon, and thyroid are other radiosensitive organs.

Excess Lifetime Cancer Risk (ELCR)

The equation below can be used to determine the increased lifetime cancer risk due to gamma radiation (Alhous et al. 2020).

$$\text{ELCR} = \text{TAED} * \text{LS} * \text{RF} \quad \dots(8)$$

where TAED (mSv.y⁻¹) presents the total annual effective dose equivalent. LS is a mean life span (approximately 70 years), and RF is the risk factor (Sv⁻¹) (Abbas et al. 2023), which reflects the fatal cancer risk per Sievert for stochastic effects. The ICRP determines the value of RF 0.05 for the public.

MATERIALS AND METHODS

Sample Description and Preparation

Thirteen types of chemical and organic fertilizers were collected from local markets. The types of examined samples were di-ammonium phosphate (DAP) fertilizer and four samples (Fig. 1). Nitrogen fertilizer for phosphorous-potassium (NPK) was three types, and organic fertilizer had six samples. The collected samples weighing about

500 grams were dried in an oven at about 110°C for 24 h to ensure complete dehumidification.

Then the samples were crushed, homogenized, and sieved through a 200 mm diameter, which is the optimal size enriched with heavy metals.

The samples were placed in a 350 cm³ polyethylene beaker. The beakers were completely closed for 4 weeks to reach temporal equilibrium when the daughters' rate of decay became equal to that of the parents.

This step is necessary to ensure that radon gas is contained within the volume and the daughters will remain in the sample (Kadhim 2020).

Instrumentation and Calibration

Samples were tested using gamma-ray spectroscopy because of the high penetrating intensity of gamma rays in materials.

A scintillation detector of the NaI(Tl) type with a dimension of 3"×3", provided by Alpha Spectra, Inc.-12112/3, is the core of a gamma-ray spectrometer. It is connected via an interface to a multi-channel analyzer (MCA) of the ORTEC-Digi Base with a range of 4096 channels and an ADC (Analog to Digital Converter) unit. The laboratory PC's MAESTRO-32 software was used to carry out the spectroscopic measurements and analysis (Kadhim 2020), as shown in Fig. 2.

RESULTS AND DISCUSSION

The measured activity concentrations of ²²⁶Ra, ²³²Th, ⁴⁰K, and Ra_{eq} in uniting (Bq.Kg⁻¹) for different fertilizer types were listed in Table 2.

From Table 2, the chemical fertilizers (chem. DAP) were noted to have an average concentration of ²²⁶Ra and



Fig. 1: Some of the chemical and organic fertilizer samples prepared for measurement in the laboratory.

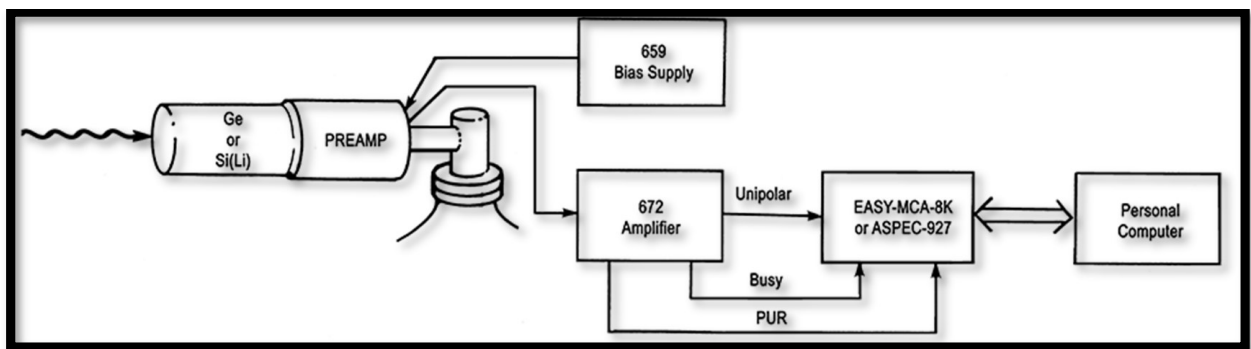

Fig. 2: Analog spectroscopy system block diagram (Constantin 2020).

Table 2: Specific activity of radium, thorium, potassium, and radium equivalent in the unit (Bq.Kg⁻¹) for all studied fertilizer samples.

Sample Code	²²⁶ Ra	²³² Th	⁴⁰ K	Ra _{eq.}
F ₁ (Chem-DAP)	50.72	34.56	660.6	151.000
F ₂ (Chem-DAP)	41.26	52.41	130.25	126.235
F ₃ (Chem-DAP)	11.15	23.40	455.72	79.7020
F ₄ (Chem-DAP)	92.51	37.79	1563.30	266.923
Min.	11.15	23.40	130.25	79.7020
Max.	92.51	52.41	1563.30	266.923
Average	48.91	37.04	702.4675	155.967
F ₅ (Chem-NPK)	26.32	79.41	168.11	152.820
F ₆ (Chem-NPK)	66.39	28.23	977.100	181.995
F ₇ (Chem-NPK)	14.63	19.43	3413.75	305.273
Min.	14.63	19.43	168.110	152.820
Max.	66.39	79.41	3413.75	305.273
Average	35.78	42.356	1519.653	213.363
F ₈ (Orga.)	31.29	24.24	944.610	138.688
F ₉ (Orga.)	23.69	23.34	640.590	106.391
F ₁₀ (Orga.)	36.20	10.78	861.730	117.968
F ₁₁ (Orga.)	39.10	26.10	3702.58	361.521
F ₁₂ (Orga.)	128.02	24.62	1612.01	287.351
F ₁₃ (Orga.)	72.62	29.81	946.030	188.092
Min.	31.29	10.78	640.590	106.391
Max.	128.02	29.81	3702.58	361.521
Average	55.153	23.148	1451.258	200.002
Worldwide UNSCEAR2000	35	30	412	370

⁴⁰K higher than what was permitted globally (UNSCEAR 2000).

While ²³²Th is within the permissible limits due to the high concentration of potassium and uranium in sample F₄ Egypt (DAP).

The mean of the three radioactive nuclei was high for the second type of fertilizer(NPK). The reason is that the percentage of phosphorous for this type is 46%.

From the same table of organic fertilizers, it was noted that the average concentration of ⁴⁰K is higher than what is recommended globally, and the reason is due to its high concentration in sample F₁₁(Iraq).

Because uranium levels were slightly higher than allowed, due to the high level in sample F12 Iran, the lowest concentration was in sample F8 Iraq, potassium in sample 9 was the lowest, and thorium was low in sample F₁₀ Iraq.

While it was concluded that the radium equivalent activity values are within the radiologically safe limits, Fig. 3 shows that (R_{aeq}) for UNSCEAR 2000 > NPK> Orga. > DAP respectively.

It can be seen that the values of activity concentrations in the studied fertilizers varied from 11.15 to 92.51, 130.250 to 1563.30, and from 23.40 to 52.41 (Bq.Kg⁻¹) for ²²⁶Ra, ⁴⁰K, and ²³²Th, respectively, for DAP chemical fertilizers. As for the chemical fertilizers of the type (NPK), the average radioactivity of the nuclides ²²⁶Ra, ²³²Th, and ⁴⁰K was 35.78, 42.356, and 1519.653 in the unit (Bq.Kg⁻¹), respectively.

Finally, the average radioactivity of the organic fertilizers was 55.153, 23.1483, and 1451.258333 for the ²²⁶Ra, ²³²Th, and ⁴⁰K nuclides, respectively. The difference in the concentration of radionuclides in the studied chemical and organic fertilizers is due to the different origins of the raw materials, the chemical treatment of the raw material during the manufacture of the fertilizers, animal feeding, and the type of plant algae. Also, the average values of radium equivalent for all types of fertilizer samples are less than the permissible activity levels, which was 370 (Bq.Kg⁻¹).

The average of the external hazard index values and the representative alpha index values were within the internationally acceptable limits. In contrast, the gamma radiation hazard index (I_γ) for most of the values was higher

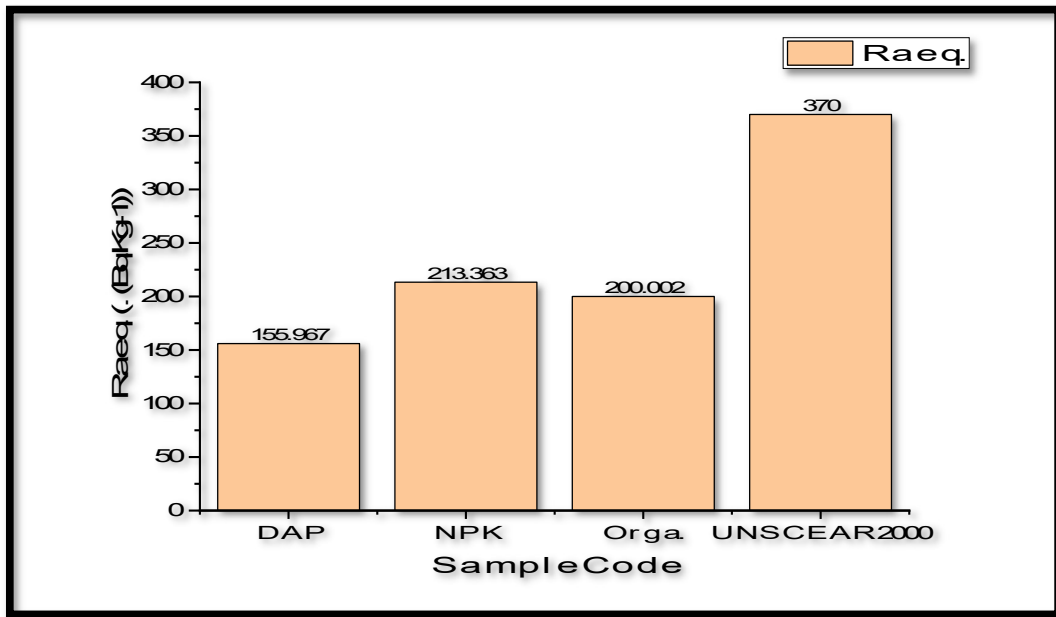

Fig. 3: Comparison of the three types of studied fertilizers with the worldwide value.

Table 3: Hazard indices for the studied samples.

Sample Code	H_{ex}	I_{γ}	I_{α}	TAED ($mSv.y^{-1}$)	AGED ($\mu Sv.y^{-1}$)	ELCR* 10^{-3}
F ₁ (Chem. _{DAP})	0.407	1.124	0.253	0.554	508.614	1.525
F ₂ (Chem. _{DAP})	0.340	0.886	0.206	0.440	387.465	1.210
F ₃ (Chem. _{DAP})	0.215	0.612	0.055	0.302	275.361	0.833
F ₄ (Chem. _{DAP})	0.720	2.036	0.462	1.001	934.694	2.754
F ₅ (Chem. _{NPK})	0.412	1.081	0.131	0.540	466.049	1.485
F ₆ (Chem. _{NPK})	0.491	1.376	0.331	0.677	629.955	1.862
F ₇ (Chem. _{NPK})	0.824	2.567	0.073	1.261	1198.342	3.469
F ₈ (Orga.)	0.374	1.080	0.156	0.532	494.616	1.464
F ₉ (Orga.)	0.287	0.818	0.118	0.403	371.908	1.110
F ₁₀ (Orga.)	0.318	0.923	0.181	0.453	427.501	1.247
F ₁₁ (Orga.)	0.976	2.990	0.195	1.468	1392.527	4.039
F ₁₂ (Orga.)	0.776	2.174	0.640	1.066	1004.665	2.933
F ₁₃ (Orga.)	0.508	1.412	0.363	0.695	646.055	1.911
Min.	0.215	0.612	0.055	0.302	275.361	0.833
Max.	0.976	2.990	0.640	1.468	1392.527	4.039
Average	0.511	1.468 > UNSCEAR 2000(≤ 1)	0.243	0.722	672.135	1.988 > UNSCEAR 2000(1.45)

than the permissible limit, perhaps due to the high values of potassium in fertilizers in general, which means that they are not internationally accepted except the F₂(Chem._{DAP}) Iran, F₃(Chem._{DAP}) China, F₉(Orga.) Iraq and F₁₀(Orga.) Iraq (Table 3).

Also noticed that the average total annual effective dose (TAED) values for all types of fertilizers are higher

than the international safe limit of 0.48 ($mSv.y^{-1}$), the lifetime cancer risk (ELCR), was higher than the worldwide (1.45×10^{-3}).

It can be noted that the values of the studied samples increased compared to UNSCEAR2000, as shown in Fig. 4. This means that there are risks when taking the average of all types.

Radioactive Variable Correlation Study Using Pearson's Coefficient

Table 4 displays the results of Pearson correlation coefficients between all the radioactive factors examined for samples of both chemical and organic fertilizers. The relationship of ^{226}Ra is weak, and it is not statistically significant with all other variables, except I_α . For the fact that it depends on its calculation on ^{226}Ra . Weak negative correlation between ^{232}Th and all studied variables in fertilizer samples. The annual gonadal dose equivalent (AGED), excess lifetime cancer (ELCR), and external hazard indices (H_{ex}) have a high good positive correlation and high statistical significance.

Accordingly, were found to have a high good positive correlation coefficient of 40K. However, a slight negative correlation coefficient was found between the studied variables. Also, due to the reliance of these two variables on particular radioactivity, H_{ex} has a substantial and statistically significant positive connection with the annual gonadal dose equivalent (AGED).

Cluster Analysis

Cluster analysis determines the optimal set of observations or objects similar to each group (CA).

Using a dendritic diagram, a multivariate technique based on similarities divides system objects into categories

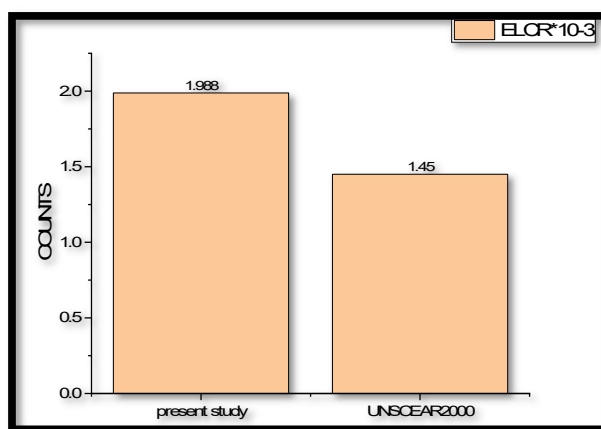

Fig. 4: Comparison of the current study with what is internationally accepted.

Table 4: Pearson correlation matrix among the radiological variables.

Variables	Correlation	^{226}Ra	^{232}Th	^{40}K	H_{ex}	I_α	AGED	ELCR
^{226}Ra	Pearson correlation	1	-.033-	0.044	0.415	1.000**	0.332	0.336
	P- value		0.914	0.887	0.158	0	0.267	0.262
^{232}Th	Pearson correlation		1	-.401-	-.124-	-.034-	-.206-	-.174-
	P- value			0.175	0.685	0.912	0.5	0.569
^{40}K	Pearson correlation			1	.889**	0.044	.937**	.929**
	P- value				0	0.886	0	0
H_{ex}	Pearson correlation				1	0.415	.993**	.995**
	P- value					0.158	0	0
I_α	Pearson correlation					1	0.333	0.336
	P- value						0.267	0.262
AGED	Pearson correlation						1	.999**
	P- value							0
ELCR	Pearson correlation							1
	P- value							

** Correlation is significant at the 0.01 level (2-tailed).

* Correlation is significant at the 0.05 level (2-tailed).

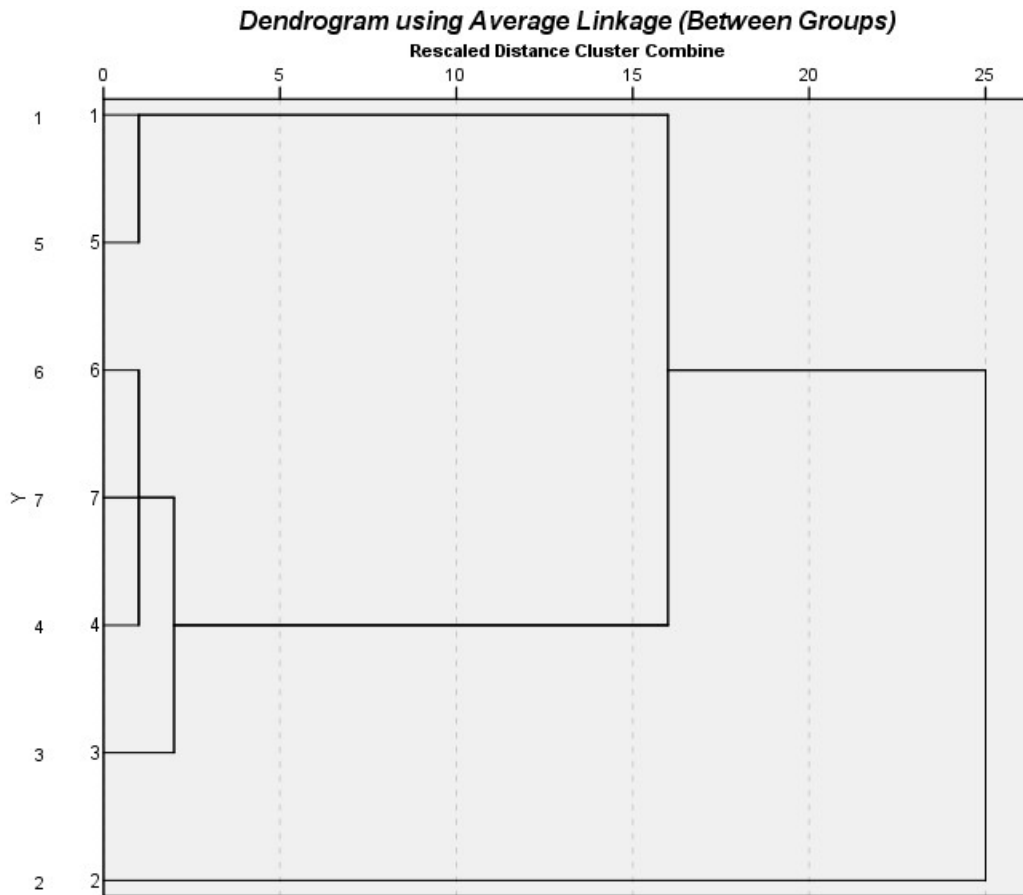

Fig. 5: Clusters of radionuclides and their radiological characteristics are displayed on a dendrogram.

or groups to visually show the order in which parameters or variables combine to produce groups with related qualities.

The first step is to group the most similar objects, and these initial groupings are created based on their shared characteristics. The maximum separation between any two individual variables and the separation between clusters are measures of similarity.

In contrast to a similarity of 0%, a similarity of 100% shows that the clusters were evenly spaced apart in the sample measurements (Guha et al. 2000). This study's cluster analysis calculates the Euclidean distance between the variables using the average linkage method. Fig. 5 displays the dendrogram that was derived. The seven parameters are arranged into three statistically significant groups in this dendrogram. Except for AGED, uranium, and thorium, all measured radiological parameters fall into Cluster 1; in contrast, Cluster 2 only includes the AGED, which is connected to uranium. Lastly, ^{40}K in cluster 3 has a large Euclidean distance. Based on already established commonalities, each cluster is created. The concentrations

of ^{232}Th and ^{40}K are the principal radioactivity contributors from Clusters 1 and 2. Yet, the uranium content is what causes the annual gonadal dosage equivalent.

CONCLUSION

The natural radioactivity and its risks were evaluated in samples of chemical and organic fertilizers by gamma-ray spectrometry.

It was the highest in radiation levels, Chem. NPK > Chem. Organic > Chem. DAP, Moreover, computed AGED was higher than ($300 \mu\text{Sv}\cdot\text{y}^{-1}$), which corresponded to a mean ELCR of (1.988×10^{-3}) that was higher than (1.45×10^{-3}). Based on these results, more samples should be studied because they pose a threat to human health, as a foregone conclusion.

Among the statistical study results using Pearson's correlation factor and cluster analysis, there are variables with strong correlation and statistical significance and others with weak correlation.

Using the average linkage method, this study's cluster analysis calculates the Euclidean distance between the variables.

These fertilizers accumulate radioactivity in the soil, which can harm the health of farmers, workers, and consumers of products grown in soils overlaid with radiation.

ACKNOWLEDGMENTS

The researchers thank and praise the University of Kufa for equipping them with research laboratories and facilities to complete this study.

REFERENCES

- Abbas, H.H., Kadhim, S.A., Alhous, S.F., Hussein, H.H., AL-Temime, F.A. and Mraity, H.A.A. 2023. Radiation risk among children due to natural radioactivity in breakfast cereals. *Nat. Environ. Pollut. Technol.*, 22(1): 527-533. <https://doi.org/10.46488/NEPT.2023.v22i01.053>
- Adhab, H.G., Kadhim alshebly, S.A. and Alsabari, E.K. 2020. Assessment excess lifetime cancer risk of soils samples in Maysan neighborhood adjacent to the middle Euphrates cancer center in Najaf/Iraq. *IOP Conf. Ser.: Mater. Sci. Eng.*, 928(7). <https://doi.org/10.1088/1757-899X/928/7/072100>
- Alam, M.N., Chowdhury, M.I., Kamal, M., Ghose, S., Islam, M.N., Mustafa, M.N., Miah, M.M.H. and Ansary, M.M. 1999. The 226Ra, 232nd, and 40-K activities in beach sand minerals and beach soils of Cox's Bazar, Bangladesh. *J. Environ. Radioact.*, 46(2): 243-250. [https://doi.org/10.1016/S0265-931X\(98\)00143-X](https://doi.org/10.1016/S0265-931X(98)00143-X)
- Alhous, S.F., Kadhim, S.A., Alkufi, A.A., Muhmood, A.A. and Zgair, I.A. 2020. Calculation of radioactivity levels for various soil samples of Karbala-Najaf road (Ya-Hussein)/Iraq. *IOP Conf. Ser.: Mater. Sci. Eng.*, 928(7): 072076. <https://doi.org/10.1088/1757-899X/928/7/072076>
- Alkufi, A.A., Alhous, S.F. and Kadhim, S.A. 2020. Annual Committed Effective dose as a result of daily Consumption of Medicinal Herbs in Iraq. *IOP Conf. Ser.: Mater. Sci. Eng.*, 928(7) 072054. <https://doi.org/10.1088/1757-899X/928/7/072054>
- Arafa, W. 2004. Specific activity and hazards of granite samples collected from the Eastern Desert of Egypt. *J. Environ. Radioact.*, 75(3): 315-327. <https://doi.org/10.1016/j.jenvrad.2004.01.004>
- Aswood, M.S. 2019. Natural radionuclides in six selected fish consumed in south Iraq and their committed effective doses. *SN Appl. Sci.*, 1(1): 1-5.
- Constantin, F. 2020. A digital positron annihilation lifetime spectrometer. *Rom. J. Phys.*, 65, 901.
- El-Taher, A. and Althoyaib, S.S. 2012. Natural radioactivity levels and heavy metals in chemical and organic fertilizers used in the Kingdom of Saudi Arabia. *Appl. Radiat. Isot.*, 70(1): 290-295. <https://doi.org/10.1016/j.apradiso.2011.08.010>
- Faweya, E.B., Ayeni, M.J., Olowomofe, G.O. and Akande, H.T. 2018. Estimation of radiation exposure in soils and organic (animal) and inorganic (chemical) fertilizers using active technique. *Int. J. Environ. Sci. Technol.*, 15(9): 1967-1982. <https://doi.org/10.1007/s13762-017-1574-x>
- Guha, S.R., Rastogi, R. and Shim, K. 2000. ROCK: A robust clustering algorithm for categorical attributes. *Inf. Syst.*, 25(5): 345-366. [https://doi.org/10.1016/S0306-4379\(00\)00022-3](https://doi.org/10.1016/S0306-4379(00)00022-3)
- Hignett, T.P. 2018. Outlook, concepts, definitions, and scientific organizations for the fertilizer industry. *Manual of fertilizer processing* (pp. 1-33. Routledge.
- Jibiri, N.N. and Fasae, K.P. 2012. Activity concentrations of 226Ra, 232nd, and 40K in brands of fertilizers used in Nigeria. *Radiat. Prot. Dosim.*, 148(1): 132-137. <https://doi.org/10.1093/rpd/ncq589>
- Kadhim, S.A. 2020. Estimated the concentration of 238U, 232nd and 40K in flour samples of Iraq markets. *J. Phys.: Conf. Ser. IOP Publ.*, 47: 101421.
- Khater, A.E.M. and Al-Sewaidan, H.A. 2008. Radiation exposure due to agricultural uses of phosphate fertilizers. *Radiat. Meas.*, 43(8): 1402-1407. <https://doi.org/10.1016/j.radmeas.2008.04.084>
- Knecht, M.F. and Göransson, A. 2004. Terrestrial plants require nutrients in similar proportions. *Tree Physiol.*, 24(4): 447-460. <https://doi.org/10.1093/treephys/24.4.447>
- Lambert, R., Grant, C. and Sauvé, S. 2007. Cadmium and zinc in soil solution extracts following the application of phosphate fertilizers. *Sci. Total Environ.*, 378(3): 293-305. <https://doi.org/10.1016/j.scitotenv.2007.02.008>
- Mohanty, A.K., Sengupta, D., Das, S.K., Saha, S.K. and Van, K.V. 2004. Natural radioactivity and radiation exposure in the high background area at Chhatrapur beach placer deposit of Orissa, India. *J. Environ. Radioact.*, 75(1): 15-33. <https://doi.org/10.1016/j.jenvrad.2003.09.004>
- Robinson, R.A. and Sutherland, W.J. 2002. Post-war changes in arable farming and biodiversity in Great Britain. *J. Appl. Ecol.*, 39(1): 157-176. <https://doi.org/10.1046/j.1365-2664.2002.00695.x>
- Stenström, K., Skog, G., Georgiadou, E., Genberg, J. and Mellström, A., 2011. A guide to radiocarbon units and calculations. (LUNFD6(NFFR-3111)/1-17/(2011)). Lund University, Nuclear Physics.
- Uosif, M.A.M., Mostafa, A.M.A., Elsaman, R. and Moustafa, E. 2014. Natural radioactivity levels and radiological hazards indices of chemical fertilizers commonly used in Upper Egypt. *J. Radiat. Res. Appl. Sci.*, 7(4): 430-437. <https://doi.org/10.1016/j.jrras.2014.07.006>
- Vincevica-Gaile, Z., Stankevica, K., Irtiseva, K., Shishkin, A., Obuka, V., Celma, S., Ozolins, J. and Klavins, M. 2019. Granulation of fly ash and biochar with organic lake sediments—A way to sustainable utilization of waste from bioenergy production. *Biomass Bioenergy*, 125: 23-33. <https://doi.org/10.1016/j.biombioe.2019.04.004>
- Ziqiang, P., Yin, Y. and Mingqiang, G. 1988. Natural radiation and radioactivity in China. *Radiat. Prot. Dosim.*, 24(1-4): 29-38. <https://doi.org/10.1093/rpd/24.1-4.29>

ORCID DETAILS OF THE AUTHORS

- Abdulhussein A. Alkufi: <https://orcid.org/0000-0002-4741-4409>
 Shaymaa A. Kadhim: <https://orcid.org/0000-0002-3991-5318>
 Azhar S. Alaboodi: <https://orcid.org/0000-0002-3029-1115>
 Shatha F. Alhous: <https://orcid.org/0000-0001-9128-099x>