

PAPER • OPEN ACCESS

Optimal DC machines performance based on intelligent controller

To cite this article: Yousif I Al-Mashhadany and Yasir Abdulhafedh Ahmed 2020 *IOP Conf. Ser.: Mater. Sci. Eng.* **917** 012084

View the [article online](#) for updates and enhancements.

INTERNATIONAL OPEN ACCESS WEEK
OCTOBER 19-26, 2020

ALL ECS ARTICLES. ALL FREE. ALL WEEK.
www.ecsdl.org

**NOW
AVAILABLE**

Optimal DC machines performance based on intelligent controller

Yousif I Al-Mashhadany¹, Yasir Abdulhafedh Ahmed²

^{1,2} Department of Electrical Engineering, College of Engineering, University of Anbar, Al-Anbar, Iraq

Email: yousif_phd@hotmail.com

Abstract. The disorganized neural controller links the calculation of the delicate rationale to the architecture of a five-layer pseudo-nervous system. The classical PID controller was replaced by an Adaptive Neuro Fuzzy Inference system (ANFIS), that will be adjusts the thin induction framework with the calculation of learning in half and a half; this makes the thin framework for learning. A fuzzy nervous-based vector display controls a frame under control. This paper displays an optimal performance with speed controller based on the drive of a power system. The proposed Neural Fuzzy Control Unit combines of a thin Boolean arithmetic calculation and five layers mock neural network system (ANN) structure, which fine-tunes the delicate deduction framework with a half and a half learning arithmetic. This makes a thin framework for learning. The proposed drive recruiting engine exhibition controlled by neurotransmitters is examined in different working conditions. The consequences of the proposed console contrast with those obtained by a regular PI controller and Fuzzy Logic controller. The study of reproduction shows the drive's strength and reliability for superior driving applications. Structural reconstruction is accomplished through applying of Matlab Verson 2019b. DC machine is a contextual search. Palatable results were obtained; this demonstrates the capability of the ANFIS console in control using a high non-linear dynamic frame and great results can be obtain by tuning the intelligent controller.

1. Introduction

Fuzzy Logic Controller gives great and quicker control [1-7], In addition to not needing a precise mathematical model of the system and is characterized by good performance for a multi-dimensional system, complex and non-linear with different parameter or minimal accurate signals. The essential problem of design is to define a coordinated and perfect list of rules and compose of functions to membership. It requires a long time and lengthy and try and error process to obtain the required response. In addition, ANN alone is not sufficient in case of insufficient training data to monitor all operating conditions [8-13].

An Adaptive Neuro-Fuzzy Inference System (ANFIS) applied as a smart equipment for FLC design [14,15]. It assists to create and improve membership functions in addition to rule base despite the simplicity of the data available. ANFIS is integrating the knowing energy of neural network with fuzzy logic knowledge exemplification. This work presents a new speed control plan of vector



controlled IM based Neuro-fuzzy controller (NFC) [16-19]. By means of hybrid learning algorithm the proposed NFC is adapted so as to reduction of the error square between both of actual and desired output. In order to train the FLC parameters, the structure of 5-layer ANN is used, this process will lead to elimination unwanted trial and error in the same way of classical fuzzy logic control. For a vector controlled IM engine that includes the proposed NFC technology, an integrated simulation model has been created, and examined the performance of the proposed NFC-based IM drive under different operating conditions [20-23]. Then, comparison was done with the normal PI speed and the response of the speed control of Fuzzy Logic. Figure 1 shows a fuzzy control system block diagram which consists of four elements as below [24,25]:

- 1) This part simply is a linguistic rule that are obtained from experts presents for how to obtain an optimal control in addition it's possible to extract of rules from a numeric data.
- 2) Inference technique (may called as a fuzzy inference system), which simulate the decision done from experts in explained and utilizes knowledge about the perfection in controlling the station.
- 3) Fuzzification interface: modify the inputs of the controller to information, which the inference technique can easily utilize in order to apply and activate rules.
- 4) Defuzzification interface: modify the outcomes of the inference technique to real inputs to the process.

For selecting the fuzzy controller outputs and inputs, the controller must be design to automate how the expert whom is felicitous in this mission could control the system. The experts (the fuzzy controller designers) inform us what information that the users can use as inputs to process of decision-making [27-29].

$$e(t) = r(t) - y(t), \quad \frac{d}{dt} e(t) \quad (1)$$

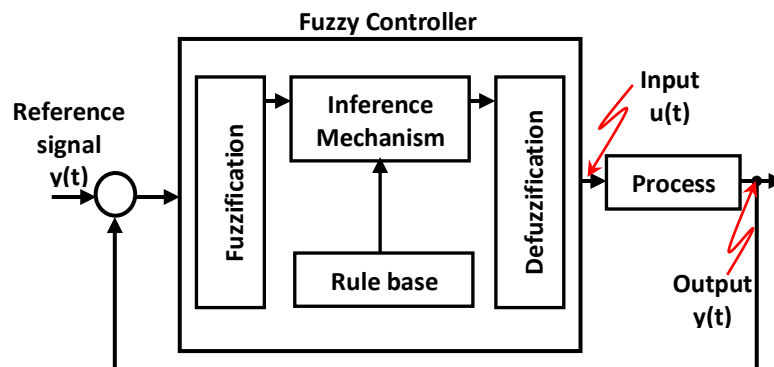

Figure 1. Block Diagram of Fuzzy Logic Controller [26]

There are many other options (such as using the embedded e-error) this option will make valid intuitive sensation. So, the controlled parameter which that belongs to the fuzzy controller will denoted as $u(t)$. This work will take an incremental variation in the output of controller as an output value. This be beneficial for general rule base to any fuzzy controller type (like PI, PID, or PD). After selection of inputs and outputs that belong to the controller immediately, it must be thinking by; what is the nature of membership functions (MFs) to these outputs and inputs parameters. After inspect the literature and for two inputs fuzzy controller; (MFs) of (3, 5, 7, 9 or 11) for every input be largely used. It's common see which, when numbers of MFs are between the determine ranges are greater, hence conceivable rules will increase as well as the response are going to be good. For this work, each (MFs) of controller inputs i.e. (e and Δe) as well as incremental changes in controller outputs i.e. (Δu) are describe in common normalize field. in the same way, all the others MFs if the number is 3, 5, 9 or 11 may be divided to the normalize field [7,8].

Then, the designing of rule base (RB) is the following step. The incremental changes in controller outputs Δu of the fuzzy controller is defined by rules refers to the formula:

$$\text{when } e \text{ is } E, \quad \Delta e \text{ is } \Delta E, \quad \text{hence } \Delta u \text{ is } \Delta U \quad (2)$$

The rule bases set of computing the outputs are perfect standardized set. In case of MFs inputs number are 7 then correspondent rules be ($7^2 = 49$). Likewise, for all another cases, the possible rules will be; ($3^2=9$, $5^2=25$, $9^2=81$, and $11^2=121$). This is the most utilized RB. In addition, it has been designed based on two-dimensional phase plane considerable when was FLC drives the system into the supposed sliding mode. A RB 1 for 9 rules, RB 2 for 25 rules, RB 3 for 49 rules and RB 4 for 81 rules.

2. Process of fuzzy inference

The process of Fuzzy inference is a five parts process [4,8,9]: the first is fuzzification the inputs variable, second is application of fuzzy operator (Or or AND) in previous, third is modulation from the previous to the consequents, fourth is consequents assembling by the rules, and the fifth is defuzzification. Sometimes these odd and cryptic names have a much specified meaning defined as the steps below.

Step One: Fuzzify inputs

Step one presents of determination the degree to which the inputs belong to every of the convenient sets of fuzzy across the membership functions (MF). The toolbox software of Fuzzy Logic, inputs are always a crisp numerical quantity related to the world of discourse of input variables (The period in this case is between digits 0 and 10). The outputs are membership fuzzy degree in the set of qualifying linguistic (the period always between the digits "0" and "1"). Fuzzification of inputs value to either, table lookup or functions estimation.

Three rules were used to construct this example, also each one of the rules build on resolve input values into various number of fuzzy linguistic sets such as: poor services, good services, stinky foods, scrumptious foods, and etc. The input values must be fuzzified before the evaluations of rules and that is done depend on each of mentioned linguistic sets.

Step Two: Fuzzy operator applied

The input values are fuzzified after that, it will be known the degree for which each portion of the previous each rule is satisfied. Now, when the previous of a specific rule have larger than single portion, so the fuzzy operator will apply to get a single number to represent the resultant of the previous of this one rule. Then, this number be execute on the output function. The Value of the input of fuzzy operator now is "2" or greater than "2" membership value from fuzzified inputs parameter. Value of the output will has be a single real value.

According to which mentioned in section of Logical Operations; in well-defined method, any number can fill out for OR operation or for AND operation. Prod (product), min (minimum) are two supported built-in AND methods, max (maximum) and (probor) probabilistic of OR are also Two built-in OR methods supported. The probabilistic OR method (It means an algebraic sum, too) computed according the formula

$$\text{probor}(a, b) = a + b - ab \quad (3)$$

Not only the mentioned built-in methods can be used, but your own OR or AND method can be created by simply writing a specific function and setting it to be your own method

Step Three: Implication method applied

Determination of the rule weight must be performed before using an implication method. Each one of rules own a weight (the number between 0, 1), that is applied to the specified number by the previous. In general, the weight is mostly 1, therefor it is ineffective absolutely on the procedures of implication. After some time it may be desire for weight of one rule according to another one by changing its own weight value to else not 1.

After appropriate weighting is specifying for each one of rules, an implication method is executed An outcomes now become fuzzy set which represented by a MF and this weight appropriately is as its characteristics of linguistic. The result is reforming with assisting of a function related to the previous

(single number). An input value of the implication operation has been a single number offered from the previous with the fuzzy set output. Implication must applied to each rule. Here, two built-in ways are hold up which are the similar used function by an AND method, min (minimum) which trim the outputs fuzzy set, and prod (product) that weights the outputs fuzzy set.

Step Four: Aggregate all of outputs

Due to relative of decisions with the inspecting of all of FIS rules, rules should be combined in some way so as to take a decision. The aggregation is a process that the fuzzy sets are represent the output value belong to each one of rules are combined of a single fuzzy set. The aggregation is occurs only one time for each one of the outputs value direct before fifth and last step defuzzification. The form of inputs for aggregation process is as list of trimmed functions which will return by implication process of each one of rules. An aggregation operation outputs is consider as a single fuzzy set for every output parameter.

Because of the commutative description of aggregation method (ever "should be") thus, the order that the rules executed by it is unimportant. There are three supported built-in methods which are:

- max. (maximum).
- probor. (probability "OR").
- sum. (sum of outputs set for the rules).

Step five: Defuzzify

Inputs to the defuzzification process described as a fuzzy set (an aggregate outputs fuzzy set). In addition, for the output, it is single number here. To the extent that fuzziness assists in evaluation the rules through the medium procedures. Then the required final output would be one number for each variable. Anyway, the aggregate of fuzzy set involve a scope of outputs value, hence it should be defuzzified for the purpose of resolve the one output value of the set.

The so-called of centroid calculation may be considered as a common method of defuzzification, this method is center of zone below of the curve. Five built-in supported methods are there: bisector, centroid, midst of the maximum (an average of the maximum outputs set value), smallest of the maximum and largest of the maximum.

3. Identification of the system.

ARX model is linear in nature and its most important feature that; it can be performing the structure of the model and parameter determination quickly. It appears that the performance in the above plots is satisfying but, if bested performance will required, then a non-linear model may be required. here, it will be used the Fuzzy Modeling approach ANFIS, for seeing if it can raise performance by use the fuzzy logic system.

The first needed work if using ANFIS for system determination is selection of the input. This is for determine the variables that the input arguments should be for the ANFIS model. in order to simplicity's sake, assume that "10" input nominees are there which are [y(m-1). y(m-2). y(m-3). y(m-4). u(m-1). u(m-2). u(m-3). u(m-4). u(m-5) u(m-6)], while an expected output is y(m). Sequential forward search is the common naming of the heuristic approach in the input selection process in which the inputs is chosen sequentially to improve the overall square error. That is can be perform by the search function; the results are present in plot above when 3 inputs which are [y (m-1), u(m-3), and u(m-4)] are choose with training RMSE at 0.06090, then checking of RMSE at 0.06040.

Table.1 presents a comparison between different approaches of modeling. An ARX modeling takes the lower period of time for reach to worst accuracy, while an ANFIS modeling via exhausted search spends most periods to reach to the better precision that means, if the goal is a fast modeling, then the right choice is an ARX. But if the utmost concern is precision, then it should be go to ANFIS because it is designed for higher precision and nonlinear modeling.

Table 1. Different methods comparison [30].

Model	ARX Models	ANFIS Models (sequential search)	ANFIS Models (exhaustive search)
inputs argument (no.)	017	03	03
RMSE (Training)	0.165	0.025	0.015
RMSE (Checking)	0.087	0.0096	0.0014
linear parameters (no.)	018	028	028
nonlinear parameters (no.)	00	013	013

4. The adaptive neuro-fuzzy controller

The neuro-fuzzy controller (NFC) combines fuzzy logic algorithm with "5" layers structure of artificial-neural network (ANN), see Fig.3 [31-35].

The "tuning block" is used for adjustment purpose of fourth layer parameter to achieve a correction of any deviation in control duty. Speed errors and change rate in actual speed errors are the input of the NFC, which expressed by:

$$\left\{ \begin{array}{l} \text{input 1} = \epsilon_w = w^* - w \\ \text{input 2} = \Delta\epsilon_w = \frac{\epsilon_w(n) - \epsilon_w(n-1)}{T} \times 100\% \end{array} \right\} \quad (4)$$

w*: command speed , T: sampling time.

The five- layers ANN structure of Sugeno Fuzzy (SF) model has used in the propose controller. For this ANN fivefold layers structure, the firstly layer represent the inputs. Second layer is the fuzzification. Third and fourth represent the fuzzy rule estimation. Lastly the fifth represents the defuzzification process. Figure 2 shows the two inputs first order model for SF with two rules. For first layer, each node "j" is a node function of adaptive node.

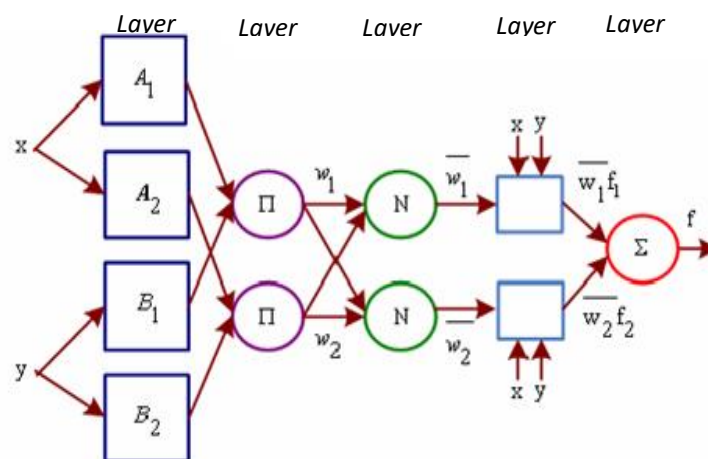

Figure 2. Two-inputs SF model ANFIS architecture with two rules [8].

$$\left\{ \begin{array}{l} O_{1j} = \gamma_{A_j}(x) \quad , \quad j = 1,2 \\ O_{1j} = \gamma_{B_{j-2}}(y) \quad , \quad j = 3,4 \end{array} \right\} \quad (5)$$

The j th node of layer l here was denoted as O_{lj} . (x or y): the input of node j . A_j, B_j are linguistic label like, 'small' or 'large' which related to remarks node. An "A" membership function would be any opportune parameters membership function. Generalized, the bell function in proposed plan represent a membership function. the formula (6) depicted that [12,13].

$$\left(\gamma_A(x) = \frac{1}{\left(1 + \left|\frac{x-c_j}{a_i}\right|^{2b_j}\right)} \right) \quad (6)$$

a_j, b_j, c_j are the parameters sets.

With changes in value of these parameters, different bell forms used as MF can be obtain for "A" (the fuzzy set). Regarding this layer, the parameters are consider as initial parameters. For second layer, each node represents fixed node named γ , and its output is the result of product of whole incoming signals.

$$O_{2,j} = w_j = \gamma_{A_j}(x)\gamma_{B_j}(y), \quad j = 1,2 \quad (7)$$

An output of each node represents rule firing strength. For the third layer, each one of nodes is fixed node marked N , and their outputs are normalize firing strength as in formula (8).

$$O_{3,j} = \bar{w}_j = \frac{w_j}{w_1 + w_2}, \quad j = 1,2 \quad (8)$$

For layer no.4, each node " j " is an adaptive node with node function, according to formula (9).

$$O_{4,j} = \bar{w}_j f_j = \bar{w}_j (p_j x + q_j y + r_j) \quad (9)$$

w_j : normalize firing strength from third layer, (p_j, q_j, r_j) are the node parameters set. For this layer, the Parameters are indicates as consequent parameters. For fifth layer, it is a layer of one node with fixing node that named as " Σ " in addition to it is calculate the total outputs as a sum of the whole signals.

$$O_{5,j} = \sum \bar{w}_j f_j = \frac{\sum j w_j f_j}{\sum j w_j} \quad (10)$$

The hybrid method converges more quickly, since it decrease the dimensions of search space of the original pure back propagation. The hybrid learning, and for back propagation, the objective function which must minimized is determined by formula (11) [14,25].

$$G_p = \sum_{m=1}^j (T_{m,p} - O_{m,p})^2 \quad (11)$$

$T_{m,p}$: the m th component of p th goal of output vector.

$O_{m,p}$: the m th component of actual output vector which created by presentation of p th input vector.

Hence, the total measured error is given by formula (12).

$$G = \sum_p^p = 1 G_p \quad (12)$$

The rules of learning can be expressed as below:

$$\begin{aligned} a_j(n+1) &= a_j(n) - \eta_{a_j} (\partial G / \partial a_j) \\ b_j(n+1) &= b_j(n) - \eta_{b_j} (\partial G / \partial b_j) \\ c_j(n+1) &= c_j(n) - \eta_{c_j} (\partial G / \partial c_j) \end{aligned} \quad (13)$$

($\eta_{a.i}, \eta_{b.i}, \eta_{c.i}$): NN learning rates.

Comparison between Mamdani and Sugeno Methods

The Sugeno system is appropriate for using the adaptive techniques in fuzzy models constructing because it's compact and computationally representation efficient is more than it is in Mamdani system. Then, these adaptive techniques will be using in customization of membership functions, so that the best models data is the fuzzy system.

The notes below illustrate some of the advantages of both the two methods above [9,33].

Sugeno Method

- It is efficient computationally.
- Good performance in linear techniques like PID control.
- Good performance for adaptive and optimization techniques.
- Has secured continuity for outputs.
- Well appropriate in mathematic analysis.

Mamdani Method

- Intuitive.
- Has a widespread approval.
- Well appropriate for human inputs.

5. Case study

MATLAB Ver. 2019b was used to simulate the case study. Two simulation methods were applied to perform the simulation process for the machine to be inspected (DC machine):

- With classical controller.
- With intelligent controller (two forms).

A proportional-integral controller used in the speed control circuit to produce the reference to the current circuit. Voltage and Current measurement blocks supply signals for the purpose of visualization. Figure 3 shows these two circuits.

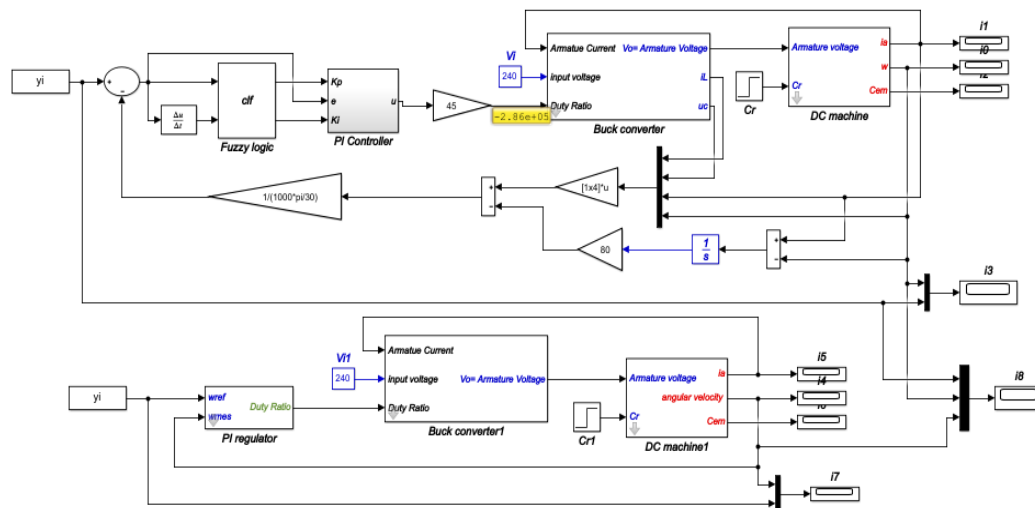

Figure 3. Simulation of DC machine with classical and intelligent controllers.

Starting of simulation, during starting and on the scope it must be inspect the motor voltage, current, and speed. The system will reach to its steady state after 1.5 second which the time of ending the simulation. Response for a changing in load torque and reference speed.

The state vector initial conditions "xInitial" starting by $\omega_m = 70$ rad/sec (then two other value 150 rad/sec and 60 rad/sec respectively). $T = 5$ N.m saved in file "power_dc drive_init.mat". The mentioned file will loaded by automatic way in the workspace once starting the procedures of simulation (return to Model Property). For using the initial or prime conditions, it must be more enable. Inspect the menu of (Simulation or Configuration) Parameters. Next, choose (Data Import or

Export) then, inspect (Initial State). Make double-click on the pair blocks of (Manual Switch) that is for switch between (Ref. Speed in rad/sec.) which is the constant and load torque (T in N.m.) block to the block of Step, (the Ref. speed Wref range between 120 rad/sec. - 160 rad/sec. at time of 0.4 sec., while torque range from 5 N.m. - 25 N.m. at time of 1.2 sec.). Hence, make (Restart) in conjunction with inspect the response of the drive to ensure sequential changed in load torque and reference - speed.

6. Simulation results

Designing simulation here was accomplished assist of ANFIS controller by Matlab Version 2019b. Software below is clarification of this simulation:

- First, appropriate the ANFIS controller configuration of as see in figure 6a. Readjust the set of inputs or outputs data, and the form of FIS functions which be using in the simulation procedures.
- Second, by means of ANFIS editor; sets all the Neuro controller identified parameters, and loading the data of inputs/outputs. The Neuro-Fuzzy controller which belong to Chopper Fed. DC machines training and the error signals of the training were illustrated in Figures (4,5,6). Network training was accomplished by algorithm of back propagation with period of 30.

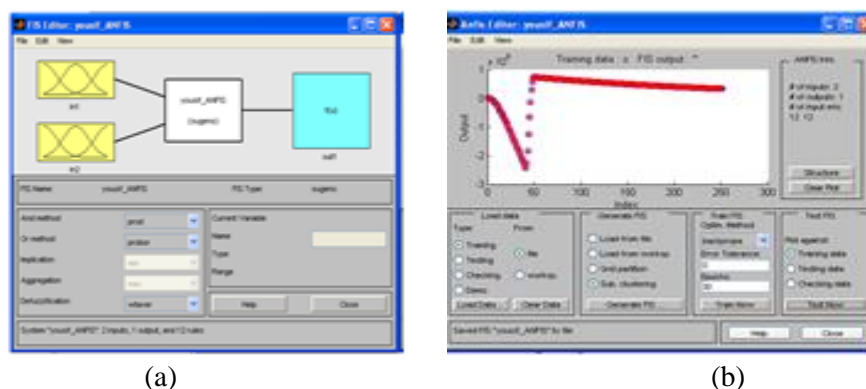

Figure 4 (a,b). ANFIS controller Training for DC machine.

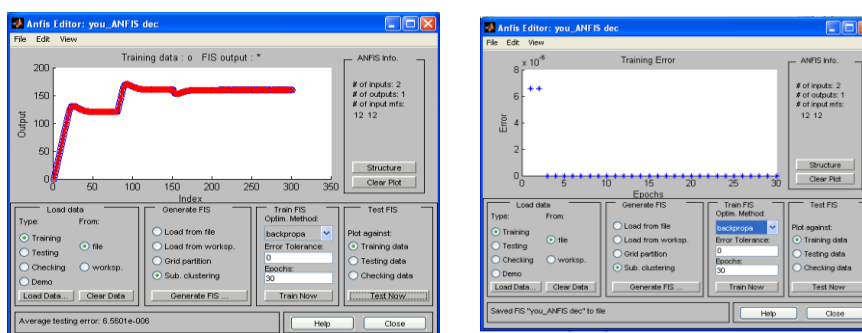

Figure 5. ANFIS controller Training for DC machine.

Figure 6. Training network Error Signals.

- 12 rules were used in the building of the ANFIS controller for DC machine, Fig.7 shows this structure, and Fig.8.a shows the form of rule , while Fig.8.b shows the membership functions of the first input.

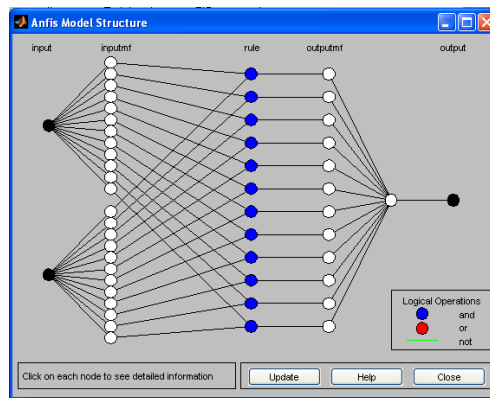

Figure 7. Structure and Rules of ANFIS Controller

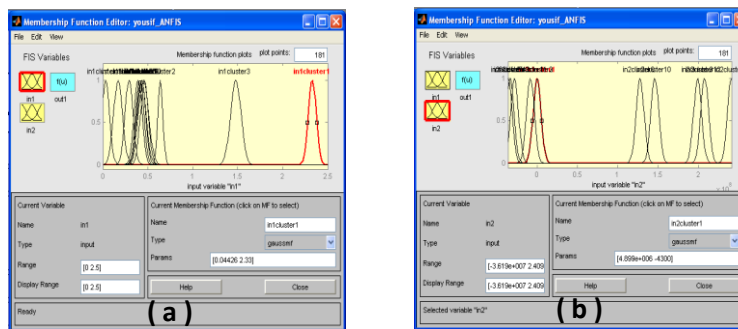

Figure 8 a,b. First & Second Inputs of Membership Functions.

- An output of the designing of DC machine is illustrates in figures (9,10) illustrate the DC machine. These results can describe all the machine parameters: speed (W. rad/sec.), the voltage and current of the armature (V_a and I_a).Figures (10) explains the speed of DC machine. The result presents the implement of three types of controllers: conventional PID controller, Fuzzy controller and Hybrid PID-fuzzy controller with optimal reference for fuzzy training. The results explains the powerful for third type (hybrid intelligent controller), all the test parameters of response with high performance.

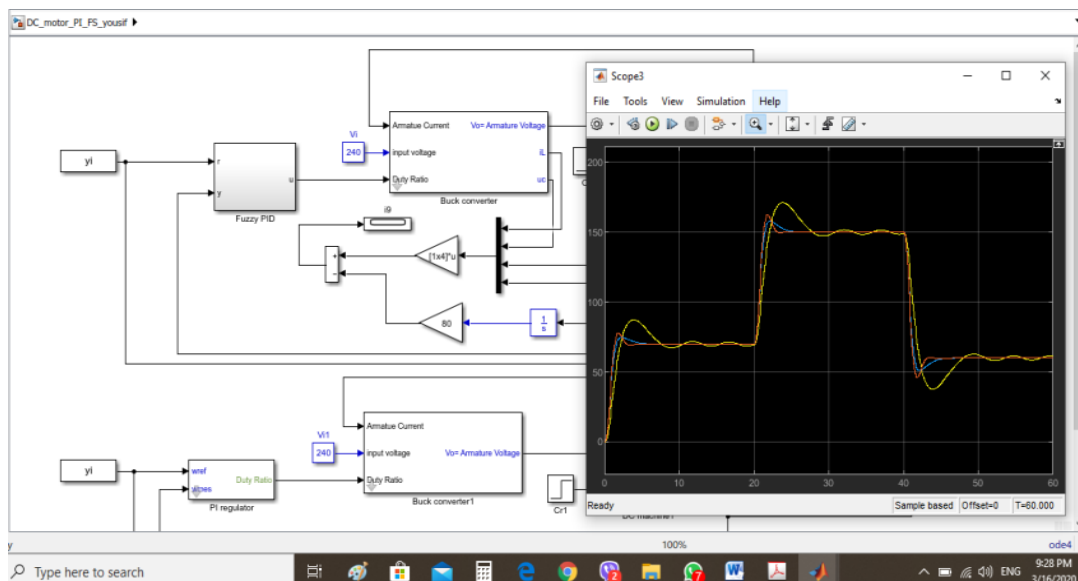

Figure 9. Simulation results of system design.

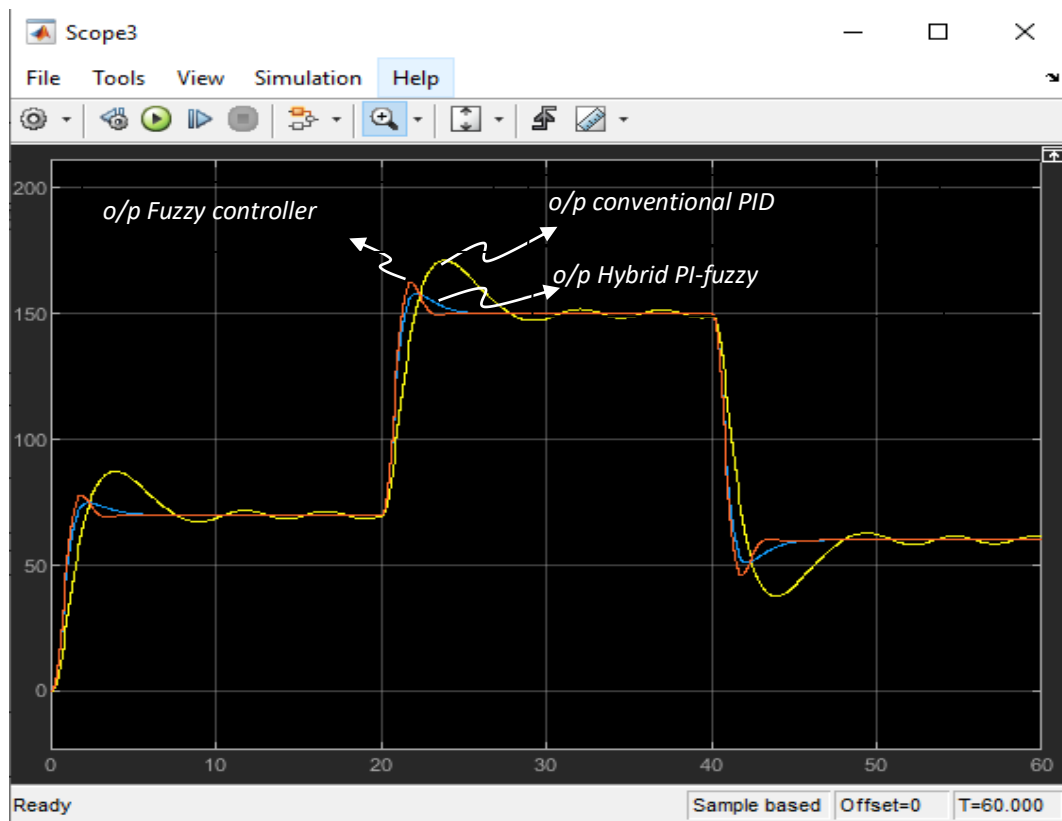

Figure 10. Simulation results of three types of controllers for system design

The results present in Fig. 10 explain improve of other type of controller. High performance appears with power systems based on hybrid controller with ANFIS system. In training procedure of controllers all the outputs have RMSE approach to zero but the best one with optimal response is the hybrid PI-ANFIS controller with RMSE is 0.000123. The proposed system can be consider hybrid power DC machine and can be consider the results as reliable and implementable with power system.

7. Conclusion

From the reenactment results can be reasoned that the ANFIS can pack the nonlinear unique framework to follow the ideal yield. This capacity is relying upon the exactness of setting for the principles of ANFIS controller. Right now, of the upsides of ANFIS are diminished number of rules, quicker speed of activity and no requirement for alterations in enrollment work by ordinary experimentation technique for ideal reaction. This makes NFC a simple form and vigorous controller. The exhibitions for NF controller based on achieved by examined at different working conditions. A presentation examination between PID based drive, FLC based drive and the proposed NFC with drive was introduced. The proposed NFC for DC machine implement as strong for superior drive application from the outcomes and diverse exploratory of different recreations can be abridged three realities that is the setting relies upon them; right off the bat, the expanding for the No. of rules doesn't fundamental expanding in the precision of results however this No. must be set with certain worth relies upon trail and blunder. Also, the principles can be decreased utilizing FSC approach and gives the comparable execution as by the bigger standard set. In any case, in FSC way to deal with pick the estimation of sweep of impact depends on hit and preliminary. Thirdly, the mistake signal in recognizable proof procedure based on the cost capacity of ideally parameters esteem, the exactness of displaying and the information with presentation of framework should be accessible purpose of getting the great outcomes with utilizing of ANFIS controller.

References

- [1] Almatheel Yasser Ali, Abdelrahman Ahmed 2017. 2017 International Conference on Communication, Control, Computing and Electronics Engineering (ICCCCEE), Khartoum, Sudan, 10.1109/ICCCCEE.2017.7867673, IEEE.
- [2] Ahmad Md. Akram, Rai Pankaj, Mahato Anita Feb 2017.. International Journal of Research in Engineering, Technology and Science, Volume VII, Special Issue, ISSN 2454-1915
- [3] ALTUN Didem Feb 2019, International Research Journal of Engineering and Technology, Volume: 06 Issue: 02, ISO 9001:2008 Certified Journal, Department of IEEE, Sivas Cumhuriyet University, Sivas, Turkey, , Page 649
- [4] Mohammed ESMAIL. S., Sedat Nazlibilek, Benkoura Fathi Sh December , International OPEN ACCESS Journal Of Modern Engineering Research, ISSN: 2249–6645, Vol. 8, Iss.12,
- [5] Weasel Noorulden Basil Mohamad, Bayat Oguz March- 2019, Int. Journal of Computer Science and Mobile Computing, Vol.8 Issue.3, pg. 152-160.
- [6] A. Siadatan , E. Yasoubi, S. Ghasemi, M. Hojjat June 2016, IEEE International symposium on power electronics, electrical drives, automation and motion, vol. 16, Italy, pp. 494-499 .
- [7] Chetan K. Lad 2017, Engineering Science and Technology, an International Journal 20 pp.1406–1419, ,
- [8] Jaya A., Purwanto E., Fauziah M.B, Murdianto F.D, Prabowo G, Rusli M.R 2017 ,(IES-ETA) International Electronics Symposium on Engineering Technology and Applications, Surabaya,.
- [9] Lokesh Kumar Agrawal, Bhavesh Kumar Chauhan, G.K. Banerjee 2018, International Journal of Pure and Applied Mathematics, Volume 119 No.15.
- [10] Verma Vishal, Chauhan ,2019 3rd International conference on Electronics, Communication and Aerospace Technology (ICECA), 1-7281-0167-5, Publisher: IEEE.
- [11] Goswamia Rakesh, Joshib Dheeraj 2018, scientific committee of the International Conference on Computational Intelligence and Data Science. Procedia Computer Science, Volume 1322018, Pages 623-631.
- [12] Ragmani Awatif, Elomri Amina, Abghour Noredine May 2,2019, The 10th International Conference on Ambient Systems, Networks and Technologies(ANT), Procedia Computer Science, Volume 1512019, , ,Leuven, Belgium. Pages 519-526.
- [13] Y. I. Al-Mashhadany 2012, published on Elsevier Procedia Engineering journal , 41, pp. 700-709
- [14] Hang Zhang, Yifeng Tu, Tao Wang January 2015, IEEE International conference on intelligent computation technology and automation, vol. 3, China, pp. 636-640.
- [15] R.Babu Ashok, and B.Mahesh kumar 2017 , International Conference on Power Engineering, Computing and Control. Doi: 10.1016/j.egypro..
- [16] Jaya A, Wahjono, Rusli M.R, Purwanto E, Murdianto F.D, Fauziah M., (IES-ETA) International Electronics Symposium on Engineerin g Technology and Applications, Surabaya.
- [17] Rakhmawati Renny , Irianto ;Murdianto , 2018 International Seminar on Application for Technology of Information and Communication, Publisher: IEEE,
- [18] Chetan K. Lad 2017 , Engineering Science and Technology, an International Journal 20 pp.1406–1419.
- [19] Y. I. Al-Mashhadany, April 2011, 2011 IEEE Applied Power Electronics Colloquium, Malaysia, pp 110-115
- [20] Kumar B. Mahesh, Ashok R. Babu, 2018, Proceedings of 2018 International Conference on Emerging Trends and Innovations in Engineering and Technological Research (ICETIETR),.
- [21] Ismail N. L. , Zakaria K. A. , Moh Nazar N. S. 2018, AIP Conference Proceedings 1930, 020026 <https://doi.org/10.1063/1.5022920>.
- [22] Roman Raul-Cristian, David Radu-Codrut 2018, The International Academy of Information Technology and Quantitative Management, the Peter Kiewit Institute, University of Nebraska, Procedia Computer Science 139 -372–380, 2018.
- [23] Y. I. Al Mashhadany, , 28th – 30th Nov. 2012, will be held in Monash University Sunway Campus, Kuala Lumpur, Malaysia

- [24] Tir Zoheir, Malik Om, Med. Assaad. Hamida October, 2017, The 5th International Conference on Electrical Engineering – Boumerdes (ICEE-B), Boumerdes, Algeria.
- [25] Divandari Mohammad, Rezaei Behrooz, Amiri Ebrahim, 2017, IEEE International Electric Machines and Drives Conference (IEMDC),
- [26] Azman M. A. H., Aris J. M., Z. Hussain, Samat A. A. A., Nazelan A. M), November 2017, 2017 7th IEEE International Conference on Control System, Computing and Engineering (ICCSCE 2017, Penang, Malaysia.
- [27] M. Akil, I. Nurtato 2017, Indonesia, Hasanuddin University, IEEE,
- [28] H. Chaundary, S. Khaton and R. Singh 2016 , 2016 Second International Innovative Applications of Computational Intelligence on Power, Energy and Controls with their Impact on Humanity (CIPECH), New delhi, India.
- [29] Y. I. Al-Mashhadany, August 24-26, 2010, International Conference on Management and Service Science (MASS 2010),.
- [30] J. Lee , J. Jiang and Y. Sun 2016, National Taipei University of Technology (Taipei Tech.), Taipei, Taiwan.
- [31] Jirapun Pongfai, Wudhichai Assawinchaichote 8-10 March 2017, International electrical engineering congress, Pattaya, Thailand.
- [32] Shivani Mishra, S.S.Thakur, S.P. . 10 October 2015, SSRG International Journal of Electrical and Electronics Engineering (SSRG-IJEEE) – volume 2 Issue.
- [33] Y. I. Al-Mashhadany 2012, published on Elsevier Procedia Engineering journal, pp 700-709
- [34] P.Hari Krishnan, M.Arjun 2016, 24th Iranian conference on Electrical Engineering.
- [35] Sharma Kartik , Palwalia Dheeraj Kumar 2017, 2017 International Conference on Information, Communication, Instrumentation and Control (ICICIC).